

PROMOTING TRUST

• SERVING YOU
STRENGTH



RHINOLOGY⁺



VORLING
instruments

HAS THE REPUTATION OF BEING THE ONLY IN PAKISTAN THAT MANUFACTURES ITS OWN TOOLS FOR THE PRODUCTION OF ITS INSTRUMENTS.

An Era Of **evolution**

VORLING instruments is a privately owned company providing personalized services and the finest in Surgical Instruments for over 25 years. Established in 1999, Our Company manufactures a wide range of Surgical, Dental and Veterinary Instruments.

All Instruments and devices of our product range are manufactured by well-trained and experienced skilled workers with special craftsmanship and by use of most modern machines and equipment. On this occasion we only use materials which meet our high standards. The CEO of Vorling Instruments, Mr. Muhammad Ahmed brings with him a lifetime of knowledge about the world of surgical instruments.

This insight allows us to understand the needs of our customers in a way most other instrument companies are unable to do.

After becoming a competent oem service provider, cardiac has decided to introduce itself as the original source of high quality instrumentation to directly interact with some of the well-known brands around the world.

Nasal Tampon Forceps, Nasal Tampon Forceps
 Nasentamponpinzetten, Nasentamponzangen
 Pinzas para taponamiento, Pinzas para taponamiento
 Pincès à pansements, Pincès à pansements
 Pinze per medicature, Pinze per medicature

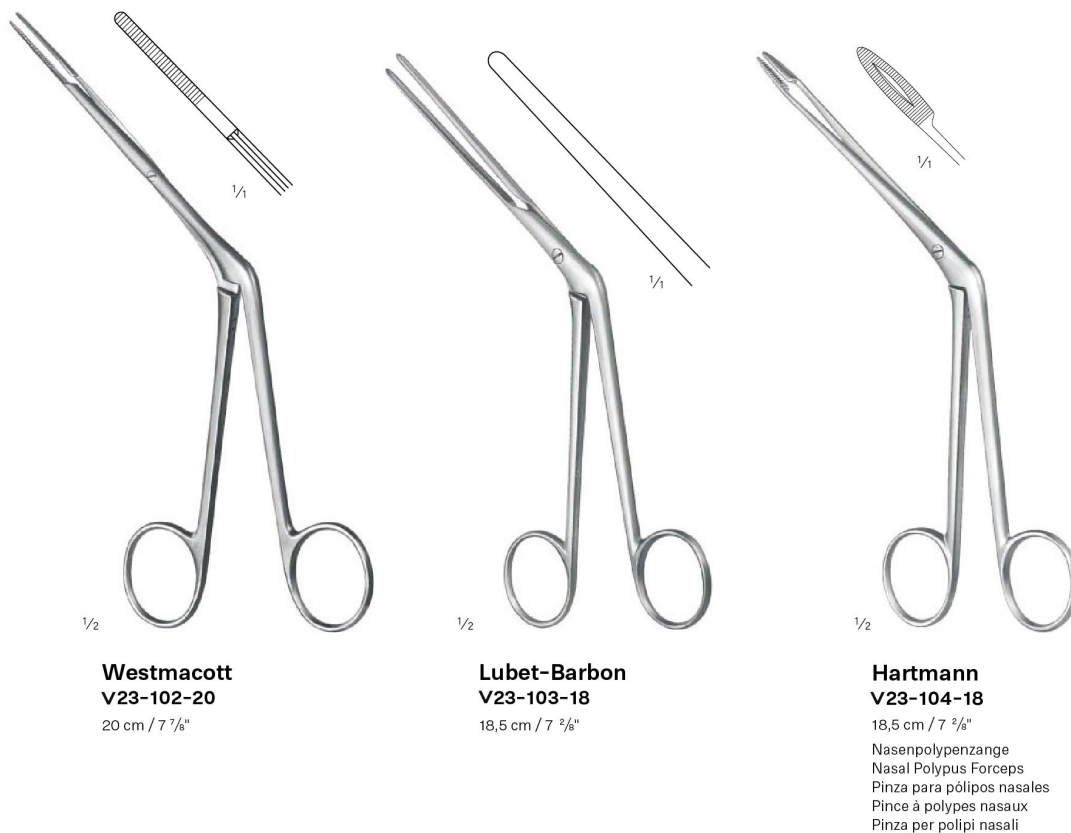
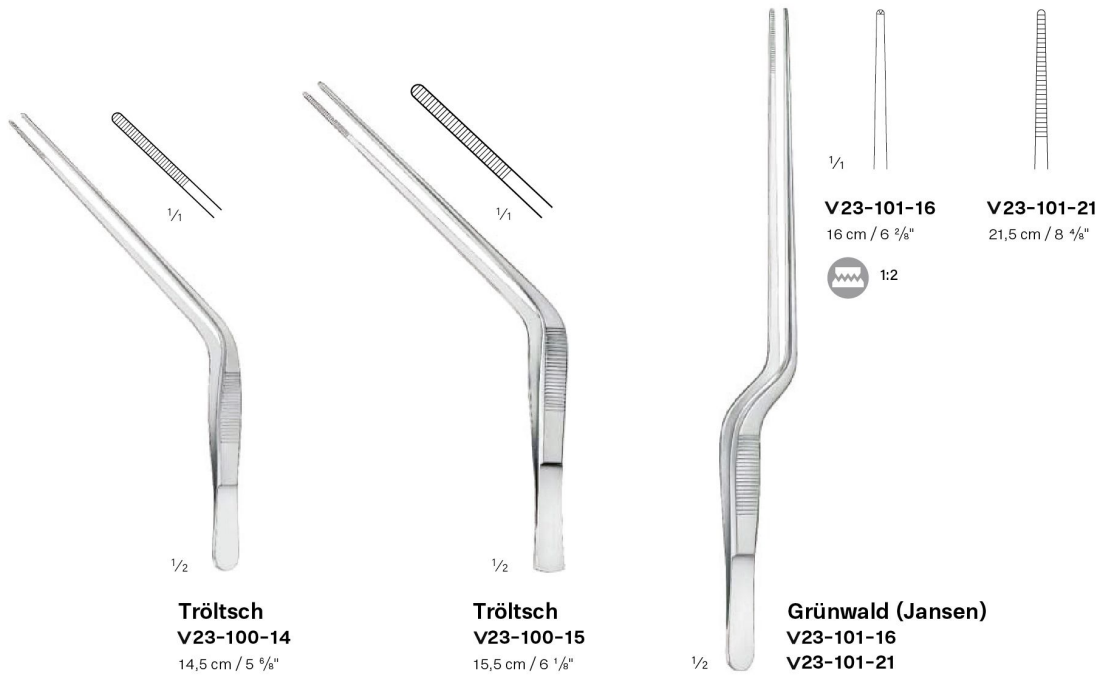

Septum Forceps

Septumzangen
Pinzas para tabique nasal
Pincas pour la cloison nasale
Pinze per il setto nasale



5,0 mm
Knight
V23-105-17
17 cm / 6 5/8"

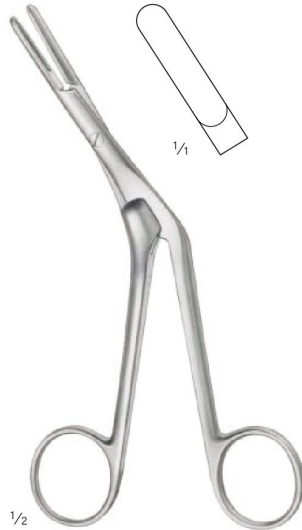

5,5 mm
Graig
V23-106-16
16 cm / 6 3/8"



V23-107-01
V23-107-02
15,5 cm / 6 1/8"



8,5 mm
V23-107-01
links gebogen
left curved
curvo por izquierdo
courbé à gauche
curvo a sinistra



8,5 mm
V23-107-02
rechts gebogen
right curved
curvo por derecho
courbé à droite
curvo a destra



Brünings
V23-108-01
V23-108-04
16,5 cm / 6 4/8"



6,6 mm
Fig. 1
V23-108-01



7,6 mm
Fig. 2
V23-108-02



8,7 mm
Fig. 3
V23-108-03



9,6 mm
Fig. 4
V23-108-04



Ethmoid Bone Forceps
 Siebbeinzangen
 Pinzas para etmoides
 Pincès éthmoïdales
 Pinze etmoidali

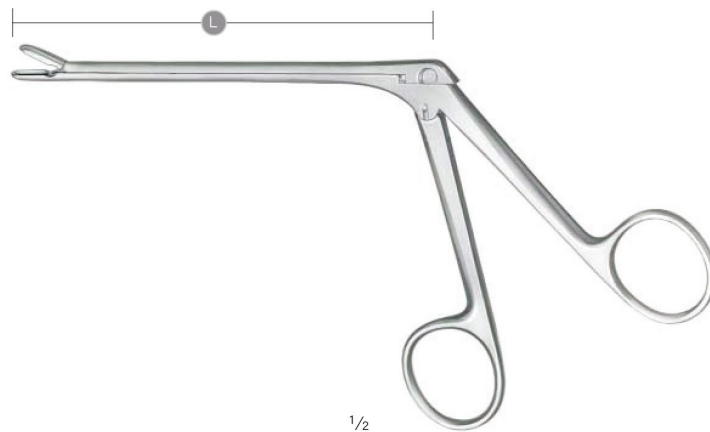

Takahashi
V23-109-12
V23-110-12

Maulbreite Jaw width Anchura de la boca Largeur de mors Larghezza della bocca	$\frac{1}{1}$ gerade straight recto droit diritto	45° aufgewinkelt angled upward acodado arrib angulé vers le haut angolato verso l'alto
	L 12 cm	L 12 cm
3,5 mm	V23-109-12	V23-110-12

Ethmoid Bone Forceps

Siebbeinzangen
 Pinzas para etmoides
 Pincas éthmoïdales
 Pinze etmoidali



23

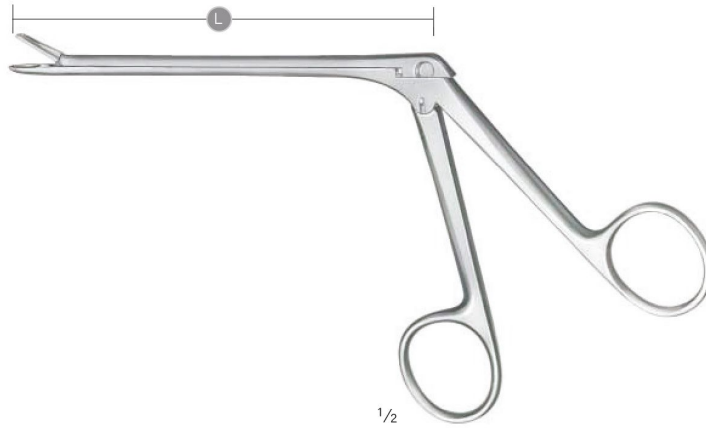

V23-111-12
V23-113-12







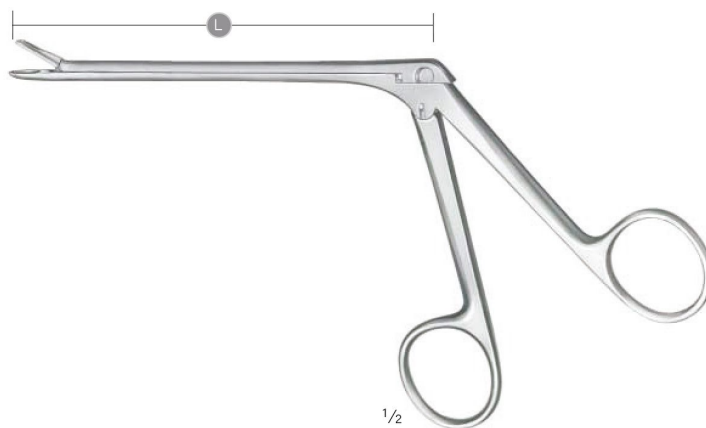







Maul Jaw Boca Mors Bocca		gerade straight recto droit diritto	gerade straight recto droit diritto	gerade straight recto droit diritto
	$\frac{1}{1}$			
		Watson-Williams		Weil
	$\frac{L}{L}$	12 cm	12 cm	12 cm
7,0 mm		V23-111-12		
8,0 mm			V23-112-12	
5,5 mm				V23-113-12

Nasal Cutting Forceps, Ethmoid Bone Forceps
 Scharfe Nasenzangen, Siebbeinzangen
 Pinzas nasales cortantes, Pinzas para etmoides
 Pincas nasales coupantes, Pincas éthmoïdales
 Pinze taglienti per il naso, Pinze etmoidali



Weil-Blakesley
V23-114-01
V23-116-04

Maulbreite Jaw width Anchura de la boca Largeur de mors Larghezza della bocca		gerade straight recto droit diritto
		 1/1 L 12 cm
Fig. 1 3,0 mm		V23-114-01
Fig. 2 3,5 mm		V23-114-02
Fig. 3 4,5 mm		V23-114-03
Fig. 4 5,5 mm		V23-114-04
Fig. 5 6,0 mm		V23-114-05

Maulbreite Jaw width Anchura de la boca Largeur de mors Larghezza della bocca		45° aufgewinkelt angled upward acodado arrib angulé vers le haut angolato verso l'alto	90° aufgewinkelt angled upward acodado arrib angulé vers le haut angolato verso l'alto
		 1/1 L 12 cm	 L 12 cm
Fig. 1 3,0 mm		V23-115-01	V23-116-01
Fig. 2 3,5 mm		V23-115-02	V23-116-02
Fig. 3 4,5 mm		V23-115-03	V23-116-03
Fig. 4 5,0 mm		V23-115-04	V23-116-04



Nasal Cutting Forceps, Ethmoid Bone Forceps

Scharfe Nasenzangen, Siebbeinzangen
 Pinzas nasales cortantes, Pinzas para etmoides
 Pincas nasales coupantes, Pincas éthmoïdales
 Pinze taglienti per il naso, Pinze etmoidali

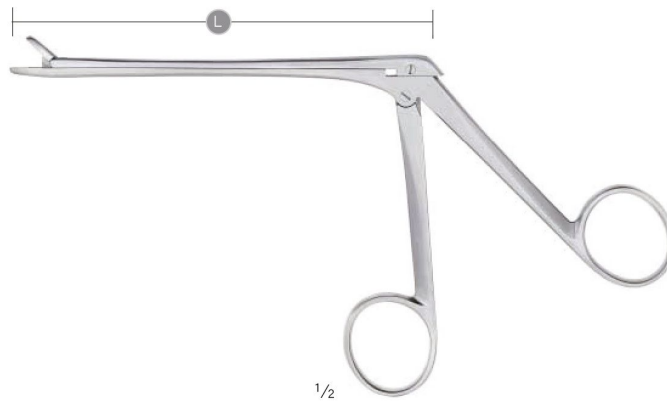

St. Barts
V23-117-12
V23-119-12





Maulbreite Jaw width Anchura de la boca Largeur de mors Larghezza della bocca	gerade straight recto droit diritto	30° aufgewinkelt angled upward acodado arrib angulé vers le haut angolato verso l'alto	30° abgewinkelt angled downward acodado abajo angulé vers le bas angolato verso il basso
			
3,0 mm	12 cm	12 cm	12 cm
	V23-117-12	V23-118-12	V23-119-12

Nasal Cutting Forceps, Ethmoid Bone Forceps
 Scharfe Nasenzangen, Siebbeinzangen
 Pinzas nasales cortantes, Pinzas para etmoides
 Pincas nasales coupantes, Pincas éthmoïdales
 Pinze taglienti per il naso, Pinze etmoidali



Struycken
V23-120-12

<p>Maulbreite Jaw width Anchura de la boca Largeur de mors Larghezza della bocca</p>	<p>gerade straight recto droit diritto</p>
<p>Fig. 1 1,0 mm</p> 	<p>$\frac{1}{4}$</p>  <p>L 12 cm</p> <p>V23-120-12</p>

Antrum Punches

Antrumstanzen
 Pinzas sacabocadas para seno maxilar
 Pincès emporte-pièces pour sinus maxillaire
 Pinze taglianti per seno mascellare

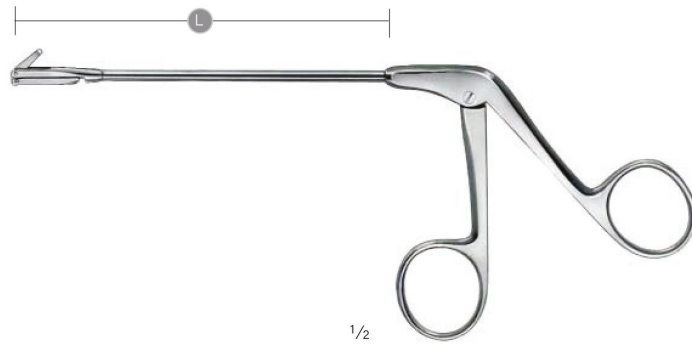

V23-121-10
V23-123-10



Maulbreite Jaw width Anchura de la boca Largeur de mors Larghezza della bocca	1/4	retrograd aufwärts schneidend retrograde, up cutting retrógrado, cortante en la parte superior retrograde, coupant en haut retrogrado, taglio in sú	retrograd rechts schneidend retrograde, right cutting retrógrado, cortante a la derecha retrograde, coupant à droit retrogrado, taglio destro	retrograd links schneidend retrograde, left cutting retrógrado, cortante a la izquierda retrograde, coupant à gauche retrogrado, taglio sinistro
	L	10 cm	10 cm	10 cm
2,5 mm		V23-121-10	V23-122-10	V23-123-10

Nasal Cutting Forceps
 Scharfe Nasenzangen
 Pinzas nasales cortantes
 Pincas nasales coupantes
 Pinze taglienti per il naso

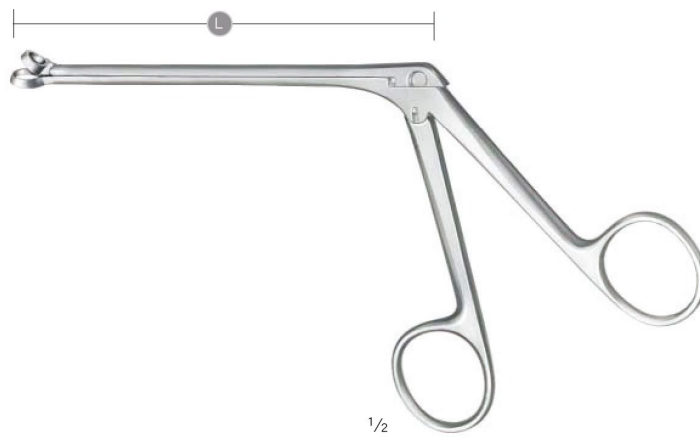

Hartmann
 V23-124-01
 V23-124-04

Schmieden
 V23-125-12

Maulbreite Jaw width Anchura de la boca Largeur de mors Larghezza della bocca	1/4	Hartmann	Schmieden
	L	12 cm	12 cm
Fig. 1 Ø 5,0 mm		V23-124-01	
Fig. 2 Ø 7,0 mm		V23-124-02	
Fig. 3 Ø 9,0 mm		V23-124-03	
Fig. 4 Ø 11,0 mm		V23-124-04	
8,0 mm			V23-125-12

Septum Forceps, Septum Morselizer

Septumzangen, Septumquetschzange

Pinzas para tabique nasal, Pinza para aplastamiento

Pinces pour la cloison nasale, Pince-gouge pour la clo

Pinze per il setto nasale, Pinza contundente per il setto nasale



Middleton-Jansen
V23-126-20
20,5 cm / 8 1/8"



Middleton-Jansen
V23-127-20
20 cm / 7 7/8"

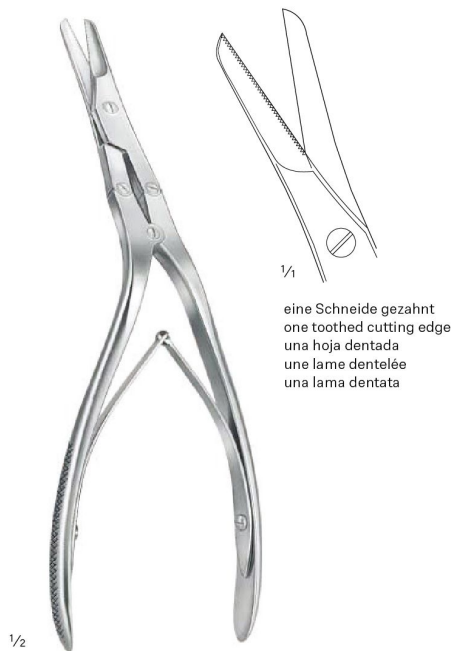

Caplan
V23-128-20
20 cm / 7 7/8"



V23-129-20
20 cm / 7 7/8"



Septum Morselizers

Septumquetschzangen
Pinzas para aplastamiento
Pincès-gouge pour la cloison nasale
Pinze contundente per il setto nasale



Rubin
V23-130-20
20 cm / 7 ⁷/₈"



Rubin
V23-131-18
18,5 cm / 7 ²/₈"

TC GOLD



Rubin
V23-132-18
18,5 cm / 7 ²/₈"



Rubin
V23-131-01
Schutzkappe
Protection Cap
Caperuza protectora
Capuchon protecteur
Calotta protettiva

 **V23-131-18**

Sphenoid Bone Punches

Keilbeinstanzen
 Pinzas sacabocadas para esfenoideas
 Pinces emporte-pièces pour sinus sphénoïdal
 Pinze taglienti per seno sfenoidale



Hajek
V23-133-03
V23-134-04



Maulbreite Jaw width Anchura de la boca Largeur de mors Larghezza della bocca	$\frac{1}{4}$	90° aufwärts schneidend cutting upward corte arriba tranchant vers le haut tagliente verso l'alto	90° abwärts schneidend cutting downward desmontable, corte abajo tranchant vers le bas tagliente verso il basso
		L	14 cm
3,5 mm		V23-133-03	V23-134-03
4,0 mm		V23-133-04	V23-134-04



Sphenoid Bone Punches

Keilbeinstanzen
 Pinzas sacabocadas para esfenoides
 Pincas emporte-pièces pour sinus sphénoïdal
 Pinze taglienti per seno sfenoidale

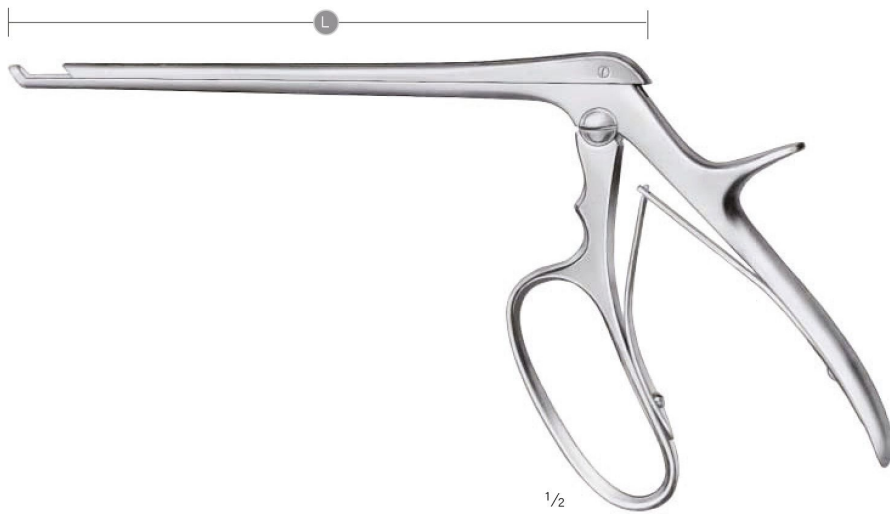

Ferris-Smith-Kerrison
V23-135-03
V23-137-05

Maulbreite Jaw width Anchura de la boca Largeur de mors Larghezza della bocca	$\frac{1}{1}$	90° aufwärts schneidend cutting upward corte arriba tranchant vers le haut tagliente verso l'alto	90° abwärts schneidend cutting downward desmontable, corte abajo tranchant vers le bas tagliente verso il basso	40° abwärts schneidend cutting downward desmontable, corte abajo tranchant vers le bas tagliente verso il basso
		18 cm	18 cm	18 cm
3 mm		V23-135-03	V23-136-03	V23-137-03
5 mm		V23-135-05	V23-136-05	V23-137-05

Sphenoid Bone Punches

Keilbeinstanzen
 Pinzas sacabocadas para esfenoides
 Pincas emporte-pièces pour sinus sphénoïdal
 Pinze taglienti per seno sfenoidale

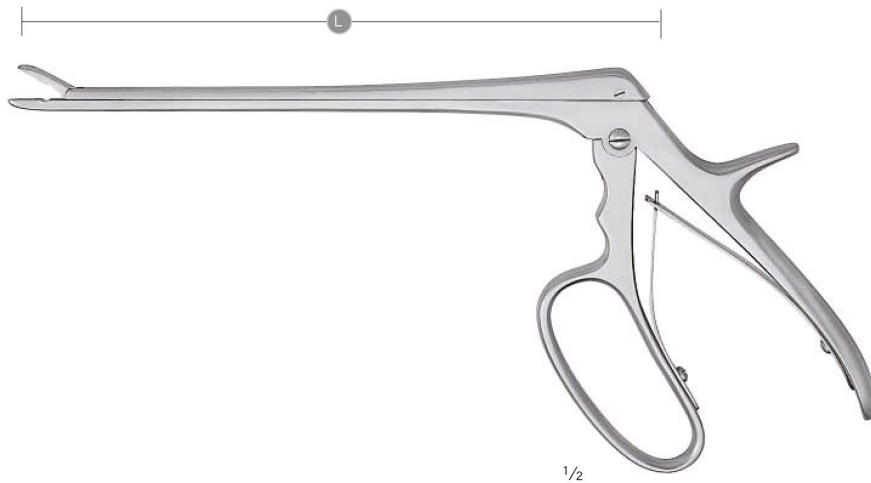

V23-138-02
 V23-140-04



Maulbreite Jaw width Anchura de la boca Largeur de mors Larghezza della bocca	1/1	gerade straight recto droit diritto	30° aufgewinkelt angled upward acodado arrib angulé vers le haut angolato verso l'alto	30° abgewinkelt angled downward acodado abajo angulé vers le bas angolato verso il basso
		L	18 cm	18 cm
10 x 2 mm		V23-138-02	V23-139-02	V23-140-02
10 x 3 mm		V23-138-03	V23-139-03	V23-140-03
10 x 4 mm		V23-138-04	V23-139-04	V23-140-04
10 x 5 mm		V23-138-05		
10 x 6 mm		V23-138-06		

Antrum Punches

Antrumstanzen

Pinzas sacabocadas para seno maxilar

Pinces emporte-pièces pour sinus maxillaire

Pinze taglianti per seno mascellare



Kerrison

V23-141-03





V23-141-06

Maulbreite
Jaw width
Anchura de la boca
Largeur de mors
Larghezza della bocca

90°
aufwärts schneidend
cutting upward
corte arriba
tranchant vers le haut
tagliante verso l'alto



L 9 cm

- 3 x 3 mm 
- 4 x 4 mm 
- 5 x 5 mm 
- 6 x 6 mm 

V23-141-03

V23-141-04

V23-141-05

V23-141-06



Rhinoplastic Knives
 Rhinoplastik-Messer
 Cuchillos rinoplásticos
 Couteaux pour plastie du nez
 Bisturi per plastica nasale



Fig. 1
V23-142-01

1/2

Joseph
V23-142-01
V23-142-02
 15 cm / 5 7/8"



Fig. 2
V23-142-02

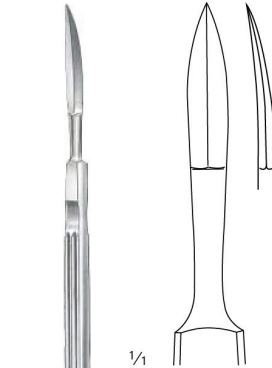

1/2

Fomon
V23-143-16
 16,5 cm / 6 4/8"



1/2

Converse
V23-144-16
 16 cm / 6 2/8"



1/4

1/2

Joseph
V23-145-15
 15,5 cm / 6 1/8"



1/4

1/2

Cottle
V23-146-14
 14 cm / 5 4/8"



Septum Knives, Swivel Knives
 Septummesser, Schwingmesser
 Cuchillos para tabique nasal
 Bistouris pour la cloison nasale
 Bisturi per il setto nasale



Freer
V23-147-16

16,5 cm / 6 5/8"
 Mukosamesser
 Mucosa Knife
 Cuchillo para mucosa
 Couteau pour muqueuse
 Bisturi per mucosa



Freer
V23-148-19

19 cm / 7 5/8"



Freer
V23-149-18

18,5 cm / 7 3/8"



Ballenger
V23-150-03
V23-150-05

21 cm / 8 2/8"



3 mm
V23-150-03



4 mm
V23-150-04



5 mm
V23-150-05



Ballenger
V23-151-03
V23-151-05

20,5 cm / 8 1/8"

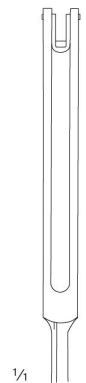

3 mm
V23-151-03



4 mm
V23-151-04



5 mm
V23-151-05

Septum Elevators

Septumelevatorien
Elevadores para tabique nasal
Elévateurs pour la cloison nasale
Elevatori per il setto nasale



McKenty
V23-152-04
V23-152-05
15 cm / 5 7/8"

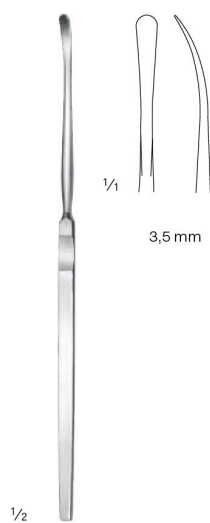

Halle
V23-153-16
16 cm / 6 2/8"



Joseph
V23-154-16
16,5 cm / 6 1/8"



Freer
V23-155-19
V23-156-19
19 cm / 7 1/8"

scharf
sharp
agudo
pointu
acuto

stumpf
blunt
romo
mousse
smusso



Krenkel
V23-157-24
V23-158-24
Gaumenraspatorium
Cleft Palate Periosteal Raspatory
Legra para el paladar
Raspoir pour palais
Raspatore per palato



Septum Elevators

Septumelevatorien
Elevadores para tabique nasal
Elévateurs pour la cloison nasale
Elevatori per il setto nasale

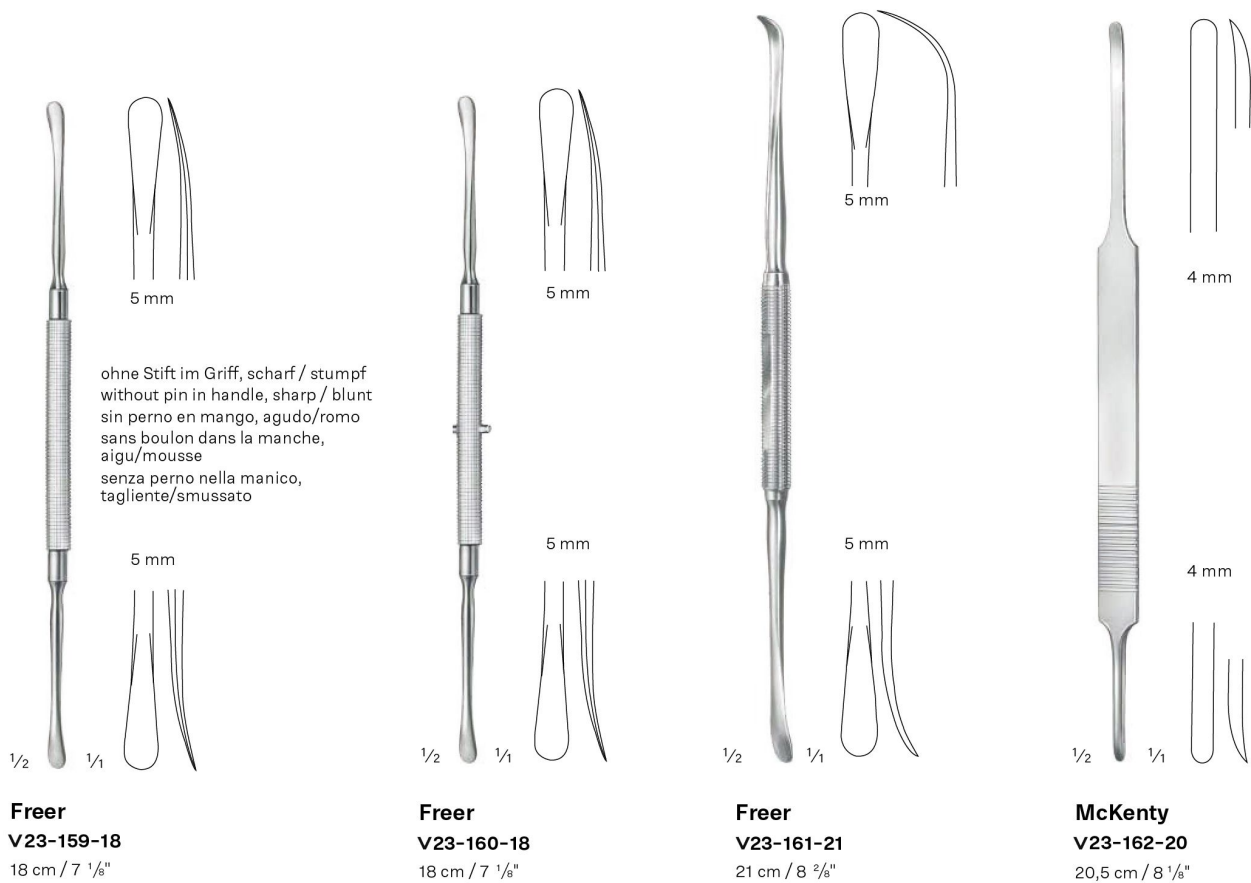

Septum Elevators

Septumelevatorien
Elevadores para tabique nasal
Elévateurs pour la cloison nasale
Elevatori per il setto nasale

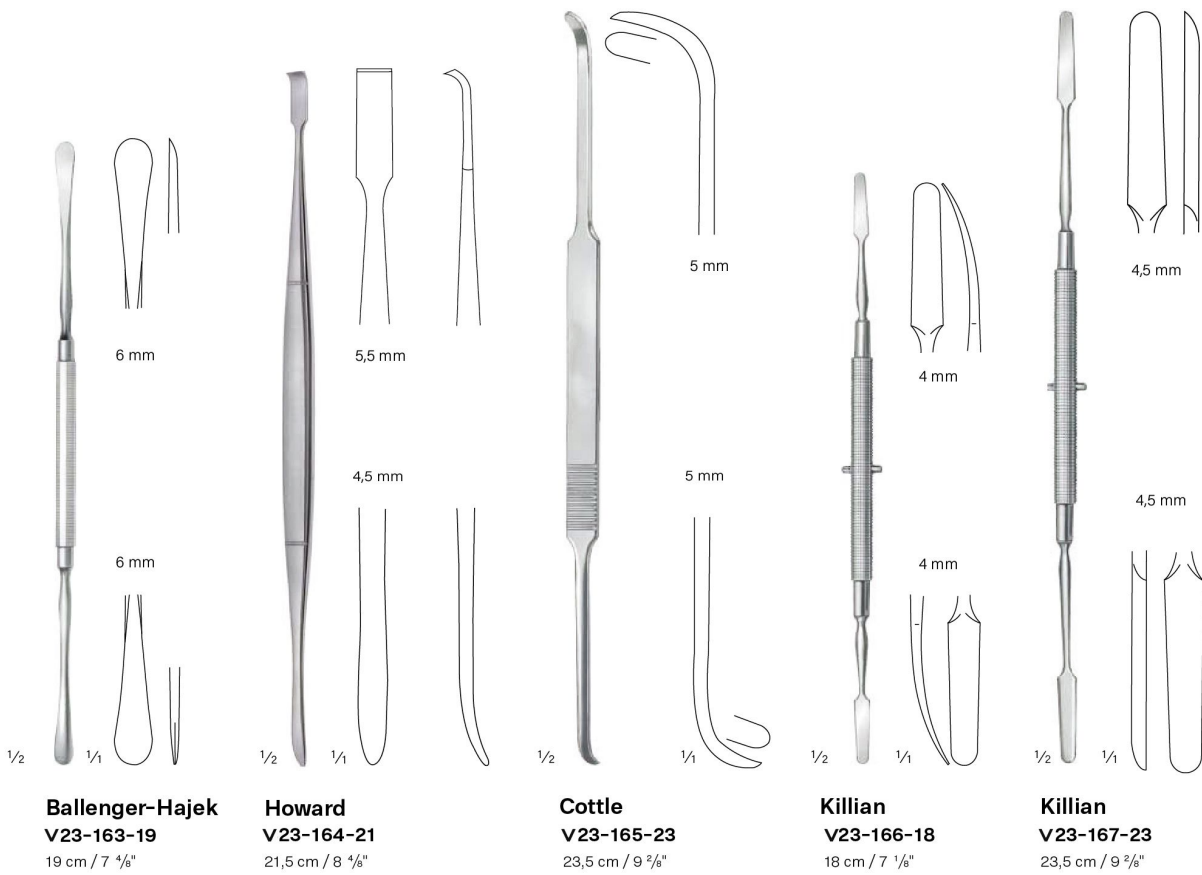

Periosteal Elevators

Periostelevatorien
Legras para periostio
Élévateurs pour le périoste
Elevatori per il periosto

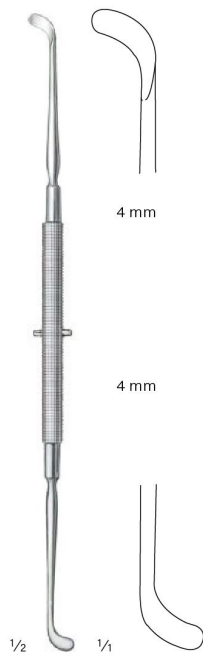

Pennington
V23-168-21
21,5 cm / 8 5/8"

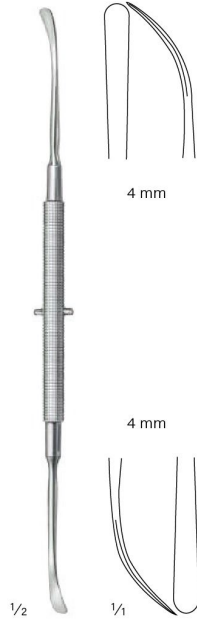

Roger
V23-169-20
20 cm / 7 7/8"



Joseph-Masing
V23-170-21
21,5 cm / 8 5/8"



Cottle
V23-171-23
23 cm / 9"



Masing
V23-172-19
19,5 cm / 7 5/8"

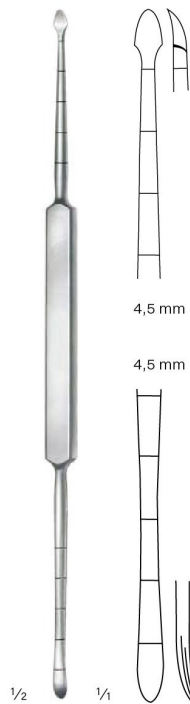

Cottle
V23-173-22
22 cm / 8 5/8"



Joseph
V23-174-18
18 cm / 7 1/8"

Septum Chisels, Septum Gouges

Septummeißel, Septum-Hohlmeißel
Cinceles para tabique nasal, Gubias para tabique nasal
Élévateurs pour le périoste, Gouges pour la cloison nasale
Elevatori per il periosto, Sgorbie per il setto nasale



Freer
V23-175-16
V23-176-16
16,5 cm / 6 5/8"

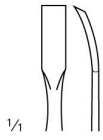

4 mm
V23-175-16



4 mm
V23-176-16



Freer
V23-177-16
16 cm / 6 2/8"

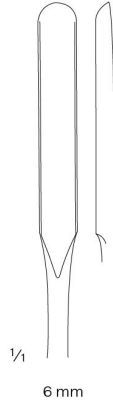

6 mm



Ballenger
V23-178-02
V23-178-08
15 cm / 5 7/8"



2 mm
V23-178-02



4 mm
V23-178-04



6 mm
V23-178-06

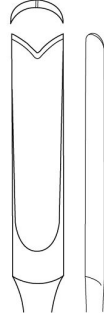

8 mm
V23-178-08



Killian
V23-179-16
16 cm / 6 2/8"

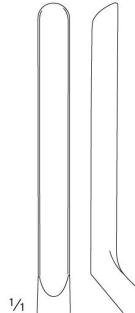

5 mm



Killian-Claus
V23-180-16
16 cm / 6 2/8"

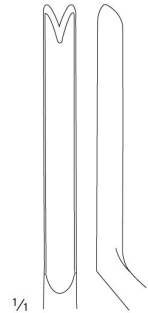

5 mm



Osteotomes

Osteotome
Osteótomos
Ostéotomes
Osteotomi

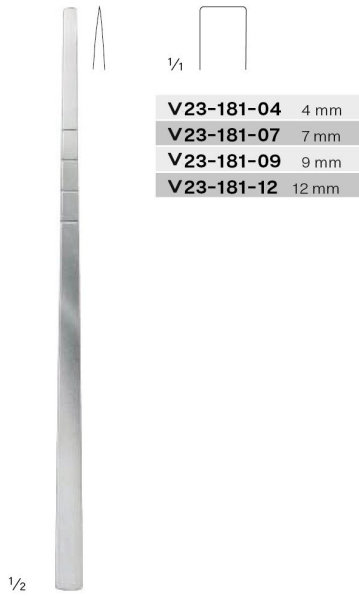

Cottle
V23-181-04
V23-181-12
18,5 cm / 7 2/8"



Cottle
V23-182-18
18,5 cm / 7 2/8"

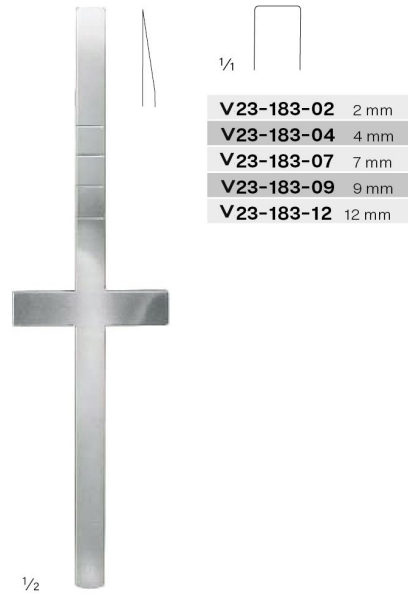

Cottle
V23-183-02
V23-183-12
18,5 cm / 7 2/8"



Cottle
V23-184-18
18,5 cm / 7 2/8"



Cottle
V23-185-18
18,5 cm / 7 2/8"

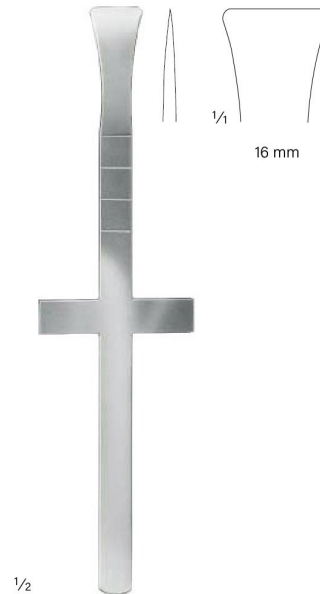

Cottle
V23-186-18
18,5 cm / 7 2/8"

Osteotomes, Chisels

Osteotome, Meißel
 Osteótomos, Cinceles
 Ostéotomes, Ciseaux-burins
 Osteotomi, Scalpelli



- V23-187-10 10 mm
- V23-187-12 12 mm
- V23-187-14 14 mm

Rubin
 V23-187-10
 V23-187-14
 18,5 cm / 7 2/8"



- 3 mm
V23-188-03
- 4,5 mm
V23-188-04

Walter
 V23-188-03
 V23-188-04
 19 cm / 7 4/8"

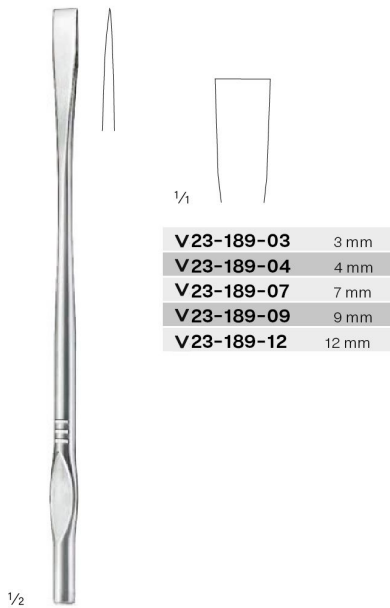

- V23-189-03 3 mm
- V23-189-04 4 mm
- V23-189-07 7 mm
- V23-189-09 9 mm
- V23-189-12 12 mm

Walter
 V23-189-03
 V23-189-12
 19 cm / 7 4/8"



- V23-190-04 4 mm
- V23-190-05 5 mm
- V23-190-06 6 mm
- V23-190-07 7 mm

Fomon
 V23-190-04
 V23-190-07
 16 cm / 6 2/8"



Rhinoplastic Chisels, Chisels

Nasenmeißel, Meißel
 Cinceles nasales, Cinceles
 Ciseaux-burins nasaux, Ciseaux-burins
 Scalpelli nasali, Scalpelli



1/2

Cinelli

V23-191-10
V23-191-16

16 cm / 6 3/8"

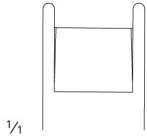

1/1

V23-191-10 10 mm

V23-191-12 12 mm

V23-191-14 14 mm

V23-191-16 16 mm



1/2

Neivert-Anderson

V23-192-01
V23-192-03

20,5 cm / 8 1/8"

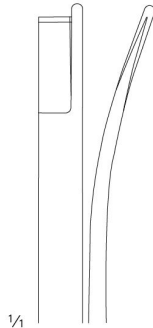

1/1

7 mm

V23-192-01

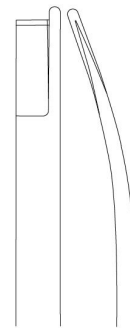

7 mm

V23-192-02



7 mm

V23-192-03



1/2

Silver

V23-193-18

18 cm / 7 1/8"

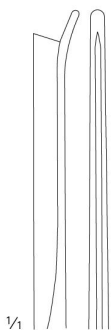

1/1

5 mm



1/2

Silver

V23-194-18

18 cm / 7 1/8"

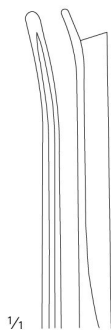

1/1

5 mm



1/2

Silver

V23-195-18

18 cm / 7 1/8"

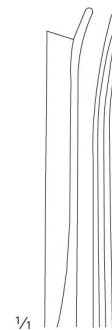

1/1

5 mm



1/2

Parkes

V23-196-16

16 cm / 6 3/8"

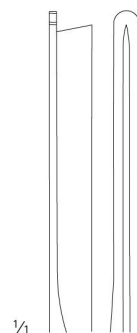

1/1



Nasal Saws
 Nasensägen
 Sierras nasales
 Scies nasales
 Seghe nasali

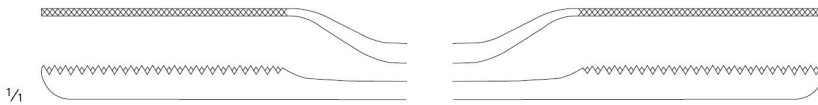

links abgewinkelt
 angled to left
 angulada por izquierda
 coudée vers gauche
 angolata a sinistra

rechts abgewinkelt
 angled to right
 angulada por derecha
 coudée vers droite
 angolata a destra

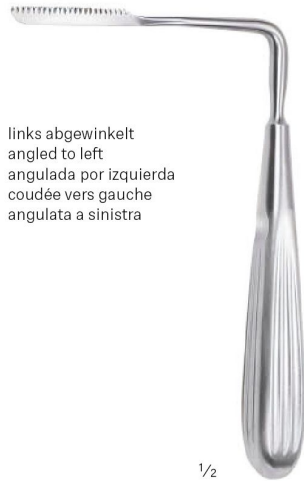

Joseph
V23-197-17
 17 cm / 6 5/8"

Joseph
V23-198-17
 17 cm / 6 5/8"

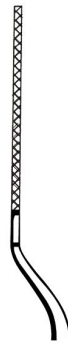
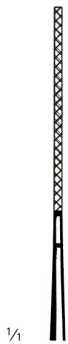

V23-199-01
 Arbeitslänge
 working length
 largo útil
 longueur utile
 lunghezza utile
 40 mm

V23-199-02
 Arbeitslänge
 working length
 largo útil
 longueur utile
 lunghezza utile
 40 mm

V23-199-03
 Arbeitslänge
 working length
 largo útil
 longueur utile
 lunghezza utile
 40 mm

Joseph
V23-199-01
V23-199-03
 19 cm / 7 1/2"



Cartilage Crusher

Knorpelquetsche
Machacadora
Pincès-gouge à cartilage
Torchio per cartilagine



1/2

Cottle

V23-200-12

12 cm / 4 7/8"

Griff
Handle
Mango
Manche
Manico



V23-200-01



1/2

Cottle

V23-200-01

Führungshilfe für Osteotome
Guide Support for osteotomes
Soporte de guía para osteótomos
Support conducteur pour ostéotomes
Supporto di guida per osteotomi

7 mm breit
7 mm wide
7 mm de ancho
largeur 7 mm
larghezza 7 mm



1/2

Cottle

V23-201-00

Knorpelquetsche
Cartilage Crusher
Machacadora
Pincès-gouge à cartilage
Torchio per cartilagine
65 x 30 x 30 mm



Nasal Rasps, Bone Files, Antrum Rasps

Nasenraspeln, Knochenfeilen, Antrumraspeln

Escofinas nasales, Limas para huesos, Escofinas para el antrum

Râpes nasales, Limes à os, Râpes pour antrum

Raspe nasali, Lime per ossa, Raspe per seno mascellare



1/2

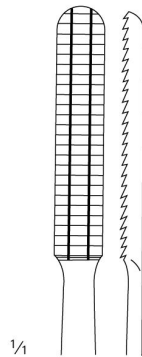

1/4

V23-202-01

auf Zug schneidend
drawing cut
cortante a tracción
tranchante à traction
tagliante a trazione
34 x 7 mm

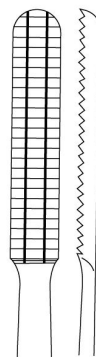

V23-202-02

auf Stoss schneidend
pushing cut
cortante a empuje
tranchante à impact
tagliante a urto
34 x 7 mm

Maltz
V23-202-01
V23-202-02
17 cm / 6 5/8"



1/2

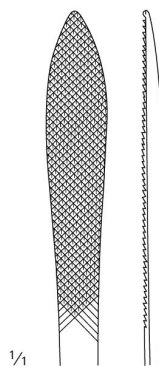

1/4

60 x 8 mm

Joseph
V23-203-16
16 cm / 6 1/8"



1/2

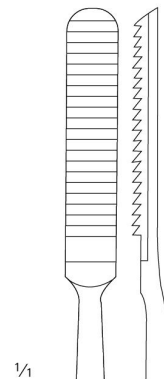

1/4

auf Zug schneidend
drawing cut
cortante a tracción
tranchante à traction
tagliante a trazione
34 x 8 mm

Cottle
V23-204-21
21 cm / 8 1/8"



Glabella Rasps, Nasal Rasps

Glabellaraspeln, Nasenraspeln
Escofinas para glabella, Escofinas nasales
Râpes pour la glabelle, Râpes nasales
Raspe per glabella, Raspe nasali



1/2

Aufricht
V23-205-01
V23-205-02
21 cm / 8 2/8"

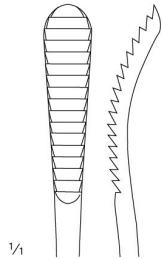

1/1

32 x 9 mm

V23-205-01

auf Stoss schneidend
pushing cut
cortante a empuje
tranchante à impact
tagliente a urto

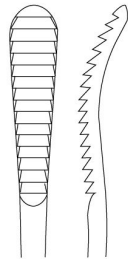

32 x 9 mm

V23-205-02

auf Zug schneidend
drawing cut
cortante a tracción
tranchante à traction
tagliente a trazione



1/2

Lewis
V23-206-01
V23-206-02
19 cm / 7 4/8"

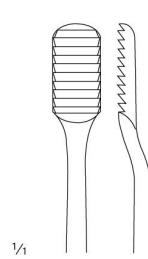

1/1

15 x 8 mm

V23-206-01

auf Stoss schneidend
pushing cut
cortante a empuje
tranchante à impact
tagliente a urto

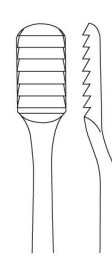

15 x 8 mm

V23-206-02

auf Zug schneidend
drawing cut
cortante a tracción
tranchante à traction
tagliente a trazione



1/2

7,0 mm
Fomon
V23-207-21
20,5 cm / 8 1/8"

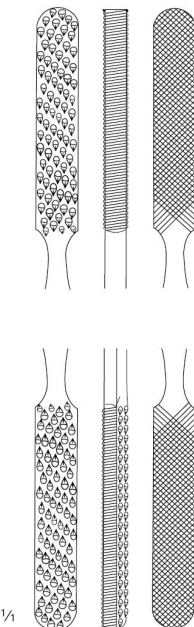

1/1

Nasal Rasps
 Nasenraspeln
 Escofinas nasales
 Râpes nasales
 Raspe nasali

TC GOLD

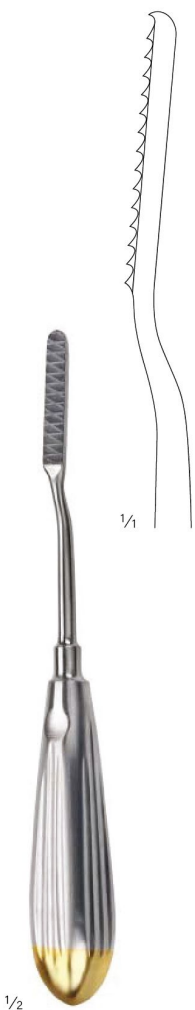

7,0 mm
Maltz
V23-208-01
V23-208-10
 21 cm / 8 3/8"

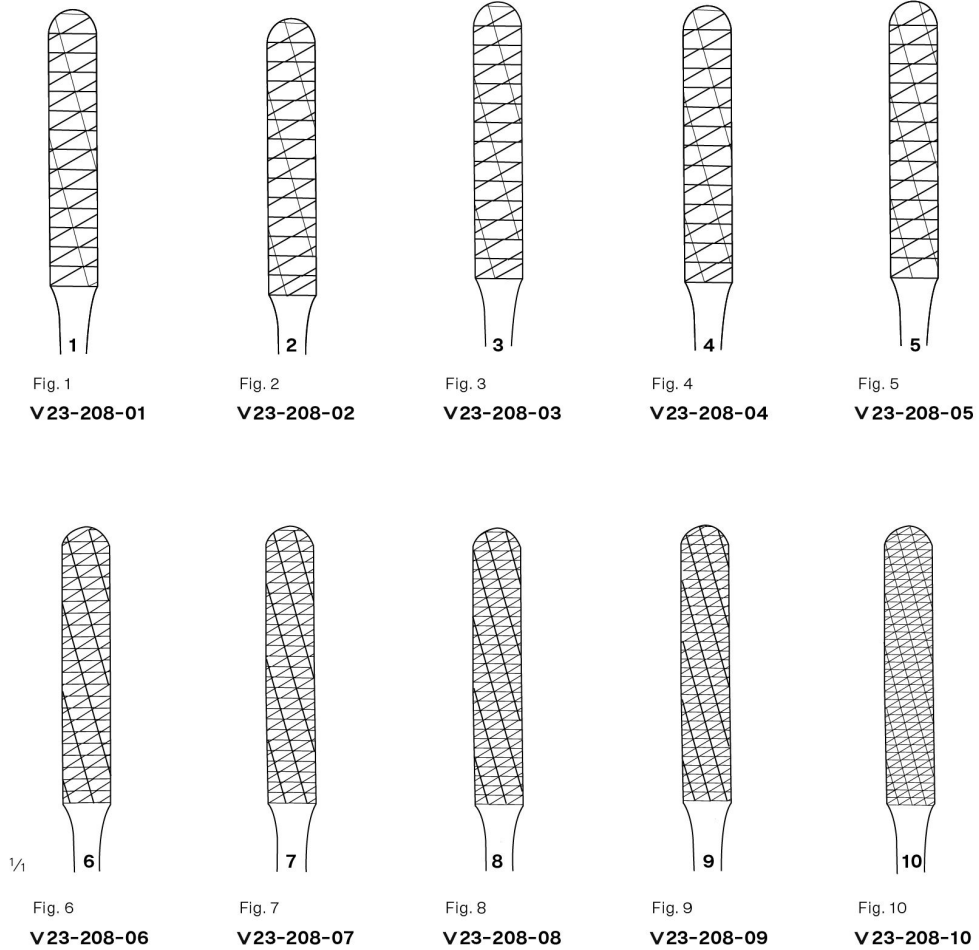

Nasal Rasps
 Nasenraspeln
 Escofinas nasales
 Râpes nasales
 Raspe nasali

TC GOLD



1/2

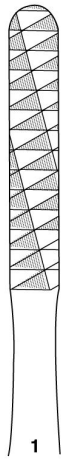

1

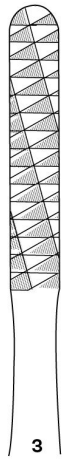

3

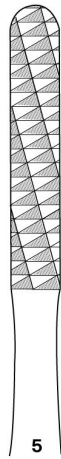

5

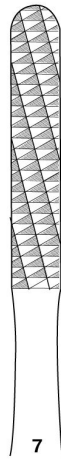

7

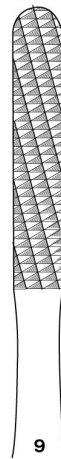

9

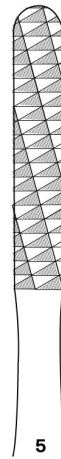

5

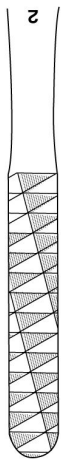

2

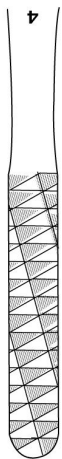

4

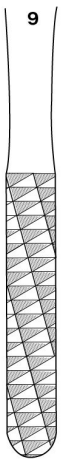

6

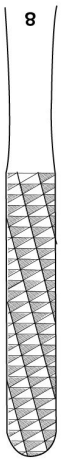

8

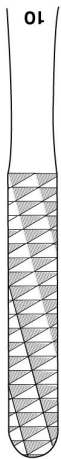

10

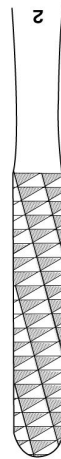

2



1/4

Fig. 1/2
V23-209-01
 30 x 8 mm

Fig. 3/4
V23-209-02
 40 x 7 mm

Fig. 5/6
V23-209-03
 40 x 7 mm

Fig. 7/8
V23-209-04
 40 x 7 mm

Fig. 9/10
V23-209-05
 40 x 7 mm

Fig. 2/5
V23-209-06
 40 x 7 mm

Fomon
V23-209-01
V23-209-06
 20,5 cm / 8 1/8"



Nasal Hooklets

Nasenhäkchen
Ganchitos nasales
Crochets nasaux
Uncini nasali

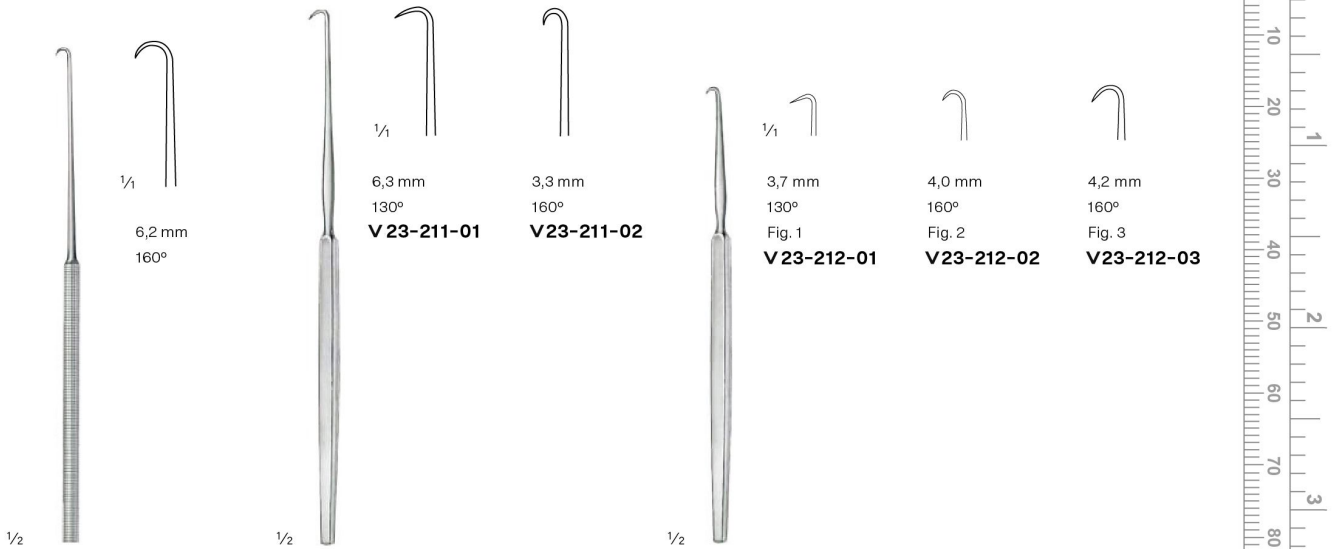

Joseph

V 23-210-15

15,5 cm / 6 1/8"

Schleimhauthäkchen, scharf
Mucosa Hooklet, sharp
Ganchito para mucosa, agudo
Crochet pour la muqueuse, pointu
Uncino per mucosa, acuto

Cottle

V 23-211-01

V 23-211-02

17 cm / 6 3/4"

scharf
sharp
agudo
pointu
acuto

Cottle

V 23-212-01

V 23-212-03

14,5 cm / 5 5/8"

scharf
sharp
agudo
pointu
acuto



Lange

V 23-213-23

23 cm / 9"

Nasenflügelhäkchen, Knopfende
Alar Hooklet, button end
Ganchito para alas de nariz, botonado
Crochet pour les ailes du nez, boutonné
Uncino per le pinne nasali, con fine a bottone



Fomon

V 23-214-17

17 cm / 6 5/8"

Nasenflügelhäkchen, Knopfende
Alar Hooklet, button end
Ganchito para alas de nariz, botonado
Crochet pour les ailes du nez, boutonné
Uncino per le pinne nasali, con fine a bottone



Aufricht

V 23-215-19

19 cm / 7 1/4"

Nasenhaken
Nasal Retractors
Separadores nasales
Ecarteurs nasaux
Divaricatori nasali

Alar Hooklets, Mucosa Hooklet

Nasenflügelhäkchen, Schleimhauthäkchen
Ganchitos para alas de nariz, Ganchito para mucosa
Crochets pour les ailes du nez, Crochet pour la muque
Uncini per le pinne nasali, Uncino per mucosa



1/2

Kilner

V23-216-08

8 cm / 3 1/8"

scharf
sharp
agudo
pointu
acuto



1/2

Converse

V23-217-10

10,5 cm / 4 1/8"

Nasenhaken
Nasal Retractors
Separadores nasales
Ecarteurs nasaux
Divaricatori nasali

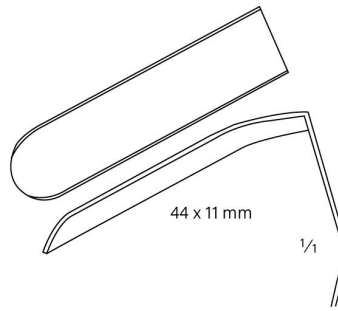

44 x 11 mm

1/1



1/2

Converse

V23-218-11

11,5 cm / 4 1/8"

scharf
sharp
agudo
pointu
acuto



1/2

Freer

V23-219-15

15 cm / 5 7/8"

scharf
sharp
agudo
pointu
acuto



1/2

Joseph

V23-220-02

V23-220-10

16 cm / 6 1/8"

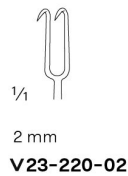

1/1

2 mm

V23-220-02

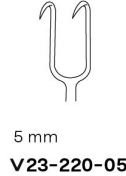

5 mm

V23-220-05

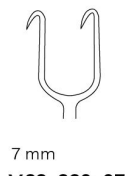

7 mm

V23-220-07

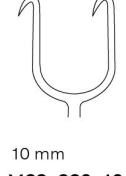

10 mm

V23-220-10

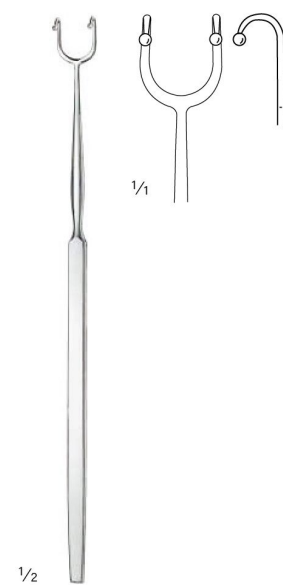

1/2

Fomon

V23-221-16

16 cm / 6 2/8"

geknöpft
button ended
abotonado
boutonné
a bottone



Alar Hooklets, Nasal Retractors

Nasenflügelhäkchen, Nasenhaken
 Ganchitos para alas de nariz, Separadores nasa
 Crochets pour les ailes du nez, Ecarteurs nasau
 Uncini per le pinne nasali, Divaricatori nasali



Cottle-Neivert
V23-222-19
 19,5 cm / 7 5/8"

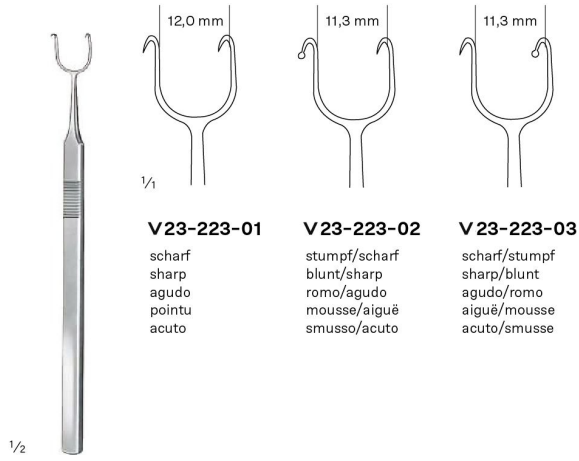

V23-223-01
 scharf
 sharp
 agudo
 pointu
 acuto

V23-223-02
 stumpf/scharf
 blunt/sharp
 romo/agudo
 mousse/aiguë
 smusso/acuto

V23-223-03
 scharf/stumpf
 sharp/blunt
 agudo/romo
 aiguë/mousse
 acuto/smusse

7,8 mm
Cottle
V23-224-14
 14 cm / 5 5/8"

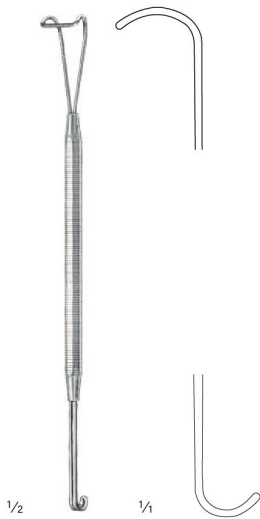

13,7 mm
Neivert
V23-225-17
 17 cm / 6 5/8"



12,5 mm
Cottle
V23-226-14
 14 cm / 5 5/8"
 Sattelhäkchen
 Saddle Hook
 Separador en forma de silla
 Elevateur sous forme de selle
 Elevatori in forma di sella



13,0 mm
Cottle
V23-227-16
 16 cm / 6 3/8"



Blätter
 blades
 hojas
 lames
 lame
 60 x 6,5 mm
Aufricht
V23-228-12
 12 cm / 4 5/8"
 stumpf
 blunt
 romo
 mousse
 smusso



Septum Forceps, Septum Straightening Forceps

Septumzangen, Septumrichtzangen

Pinzas para tabique nasal, Pinzas para enderezar el tabique nasal

Pinces pour la cloison nasale, Pinces pour le redressement de la cloison nasale

Pinze per il setto nasale, Pinze per raddrizzare il setto nasale



V23-230-01

gerade
straight
recta
droite
diritta

V23-230-02

links
left
izquierdo
gauche
sinistra

V23-230-03

rechts
right
derecho
droit
destra



Kressner
V 23-229-22
22 cm / 8 5/8"



Cottle-Walsham
V23-230-01
V23-230-03
23 cm / 9"

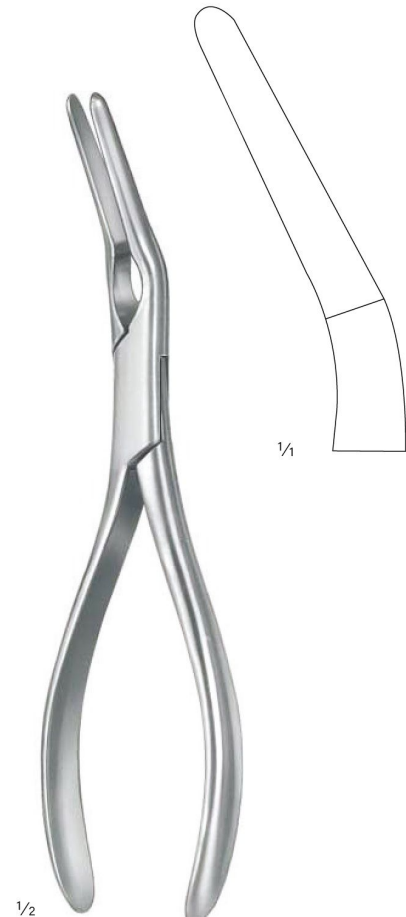

Asch
V 23-231-22
22,5 cm / 8 7/8"



Skin Grasping Forceps, Antrum Currettes

Hautfasspinzetten, Antrumküretten
 Pinzas para piel, Curetas para el antro
 Pincés pour saisir la peau, Curettes pour l'antro
 Pinze per afferrare la pelle, Curette per antro



Ogura
V23-232-11
 11 cm / 4 3/8"

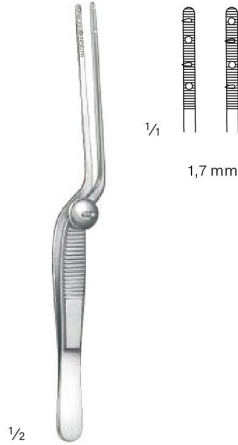

Cottle
V23-233-14
 14 cm / 5 1/2"
 mit Zähnen
 with teeth
 con dientes
 avec dents
 con denti

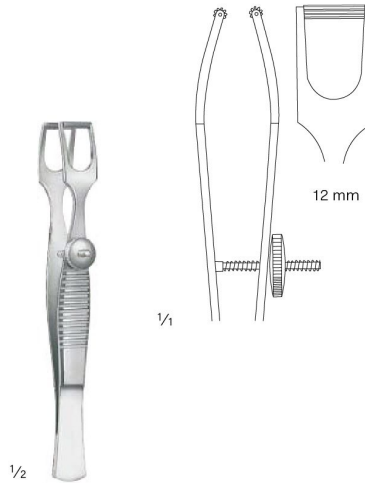

Cottle
V23-234-11
 11 cm / 4 3/8"
 Columellapinzette
 Columella Forceps
 Pinza para columella
 Pinze à columella
 Pinza per columella



Faulkner
V23-235-21
 21 cm / 8 2/8"



Coakley
V23-236-01
V23-236-06
 17 cm / 6 5/8"

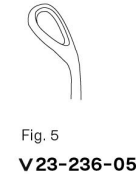
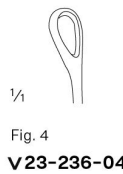
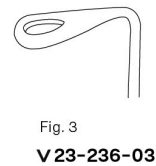
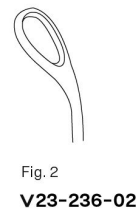
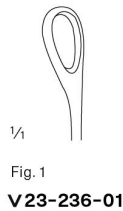

Adenoid Curettes, Suction Raspatory, Frontal Sinus Dilators

Ringmesser, Saugraspatorium, Sinus-Dilatatoren

Cuchillos para adenoides, Legra de succión, Dilatadores para el seno

Couteaux à végétations adénoïdales, Rugine-raspatoire à suction, Dilatateurs pour le sinus frontal

Cottelli per vegetazioni adenoidae, Raspatorio con aspiratore, Dilatatori per il seno frontale



Fig. 1	V23-237-01	13 mm
Fig. 2	V23-237-02	15 mm
Fig. 3	V23-237-03	17 mm
Fig. 4	V23-237-04	19 mm
Fig. 5	V23-237-05	21 mm
Fig. 6	V23-237-06	23 mm

Beckmann
V23-237-01
V23-237-06
22 cm / 8 5/8"



Fig. 1	V23-238-01	13 mm
Fig. 2	V23-238-02	15 mm
Fig. 3	V23-238-03	17 mm
Fig. 4	V23-238-04	19 mm
Fig. 5	V23-238-05	21 mm
Fig. 6	V23-238-06	23 mm

Beckmann
V23-238-01
V23-238-06
21,5 cm / 8 1/2"



Eicken-Killian
V23-239-01
V23-239-02
14 cm / 5 1/8"

Spülkanüle, mit Luer-Lock
Irrigation Cannula, with Luer-Lock
Sonda irrigadora para seno maxilar, con Luer-Lock
Canule à irrigation, avec Luer-Lock
Cannula per lavaggio, con Luer-Lock



Guilen
V23-240-19
19 cm / 7 1/2"

V23-240-90-98
Obturator
Obturator
Mandrill
Obturateur
Mandrino



Ritter-Halle
V23-241-30
V23-241-40
14,5 cm / 5 5/8"

no one does it BETTER



Cell: +92 334 6113800

URL: <https://vorlinginstruments.com>

Email: info@vorlinginstruments.com

Address:

Kacha Shahab Pura Road

Jeewan Pura, Sialkot (51310)

Pakistan.

