

# REFINED TRAIT RELIABLE TOOL

• UPGRADED  
PERFORMANCE &  
SYMBOL OF SAFETY



**SCISSORS<sup>+</sup>**



## An Era Of **evolution**

**VORLING**  
instruments

HAS THE REPUTATION OF BEING THE ONLY IN PAKISTAN THAT MANUFACTURES ITS OWN TOOLS FOR THE PRODUCTION OF ITS INSTRUMENTS.

---

**VORLING** instruments is a privately owned company providing personalized services and the finest in Surgical Instruments for over 25 years. Established in 1999, Our Company manufactures a wide range of Surgical, Dental and Veterinary Instruments.

All Instruments and devices of our product range are manufactured by well-trained and experienced skilled workers with special craftsmanship and by use of most modern machines and equipment. On this occasion we only use materials which meet our high standards. The CEO of Vorling Instruments, Mr. Muhammad Ahmed brings with him a lifetime of knowledge about the world of surgical instruments.

This insight allows us to understand the needs of our customers in a way most other instrument companies are unable to do.

**After becoming a competent oem service provider, cardiac has decided to introduce itself as the original source of high quality instrumentation to directly interact with some of the well-known brands around the world.**

---

## Operating Scissors

Chirurgische Scheren  
Tijeras quirúrgicas  
Ciseaux chirurgicaux  
Forbici per chirurgia



Size	Standard	TC Gold
12 cm / 4 <sup>5</sup> / <sub>8</sub> "	<b>V02-100-12</b>	
13 cm / 5 <sup>1</sup> / <sub>8</sub> "	<b>V02-100-13</b>	
14,5 cm / 5 <sup>9</sup> / <sub>8</sub> "	<b>V02-100-14</b>	<b>V02-101-14</b>
15,5 cm / 6 <sup>1</sup> / <sub>8</sub> "	<b>V02-100-15</b>	
16,5 cm / 6 <sup>4</sup> / <sub>8</sub> "	<b>V02-100-16</b>	
17,5 cm / 6 <sup>7</sup> / <sub>8</sub> "	<b>V02-100-17</b>	
18,5 cm / 7 <sup>2</sup> / <sub>8</sub> "	<b>V02-100-18</b>	
20,5 cm / 8 <sup>1</sup> / <sub>8</sub> "	<b>V02-100-20</b>	

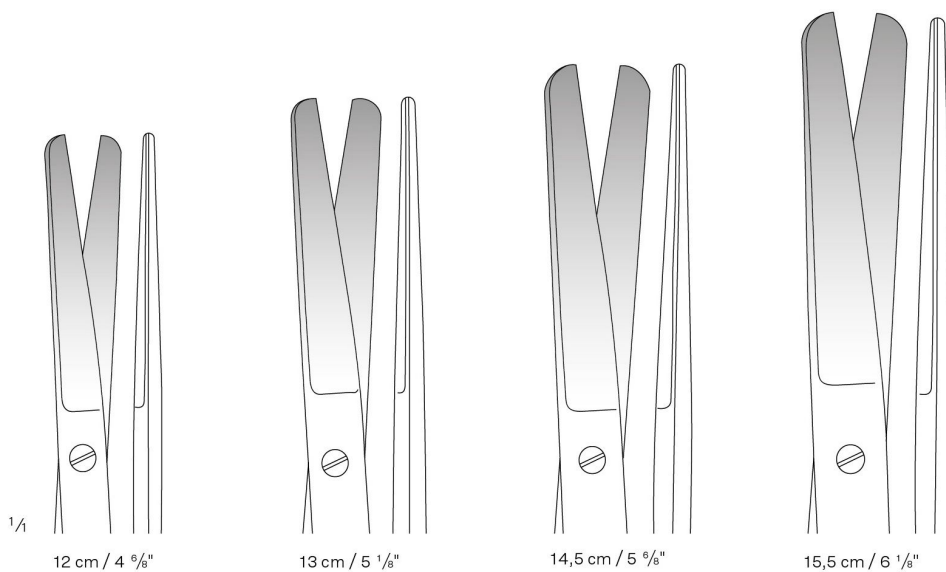

## Operating Scissors

Chirurgische Scheren  
Tijeras quirúrgicas  
Ciseaux chirurgicaux  
Forbici per chirurgia

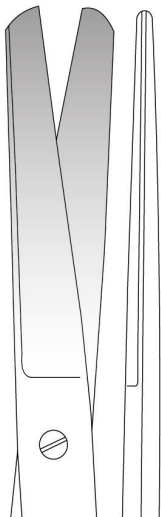

16,5 cm / 6 <sup>5</sup>/<sub>8</sub>"

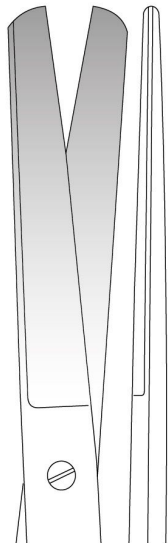

17,5 cm / 6 <sup>7</sup>/<sub>8</sub>"

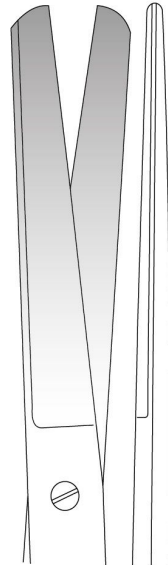

18,5 cm / 7 <sup>2</sup>/<sub>8</sub>"

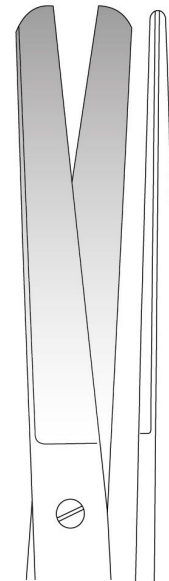

20,5 cm / 8 <sup>1</sup>/<sub>8</sub>"



## Operating Scissors

Chirurgische Scheren  
Tijeras quirúrgicas  
Ciseaux chirurgicaux  
Forbici per chirurgia



Size	Standard	TC Gold	Super Cut
12 cm / 4 <sup>9</sup> / <sub>8</sub> "	V02-102-12		
13 cm / 5 <sup>1</sup> / <sub>8</sub> "	V02-102-13		
14,5 cm / 5 <sup>9</sup> / <sub>8</sub> "	V02-102-14	V02-103-14	V02-104-14
15,5 cm / 6 <sup>1</sup> / <sub>8</sub> "	V02-102-15		
16,5 cm / 6 <sup>4</sup> / <sub>8</sub> "	V02-102-16		
17,5 cm / 6 <sup>7</sup> / <sub>8</sub> "	V02-102-17		
18,5 cm / 7 <sup>2</sup> / <sub>8</sub> "	V02-102-18		
20,5 cm / 8 <sup>1</sup> / <sub>8</sub> "	V02-102-20		

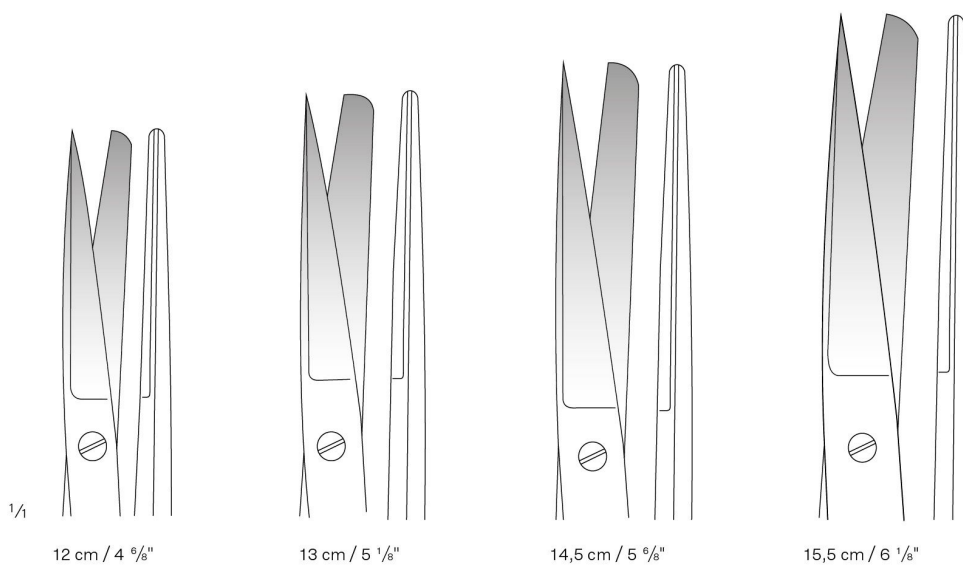

## Operating Scissors

Chirurgische Scheren  
Tijeras quirúrgicas  
Ciseaux chirurgicaux  
Forbici per chirurgia



02

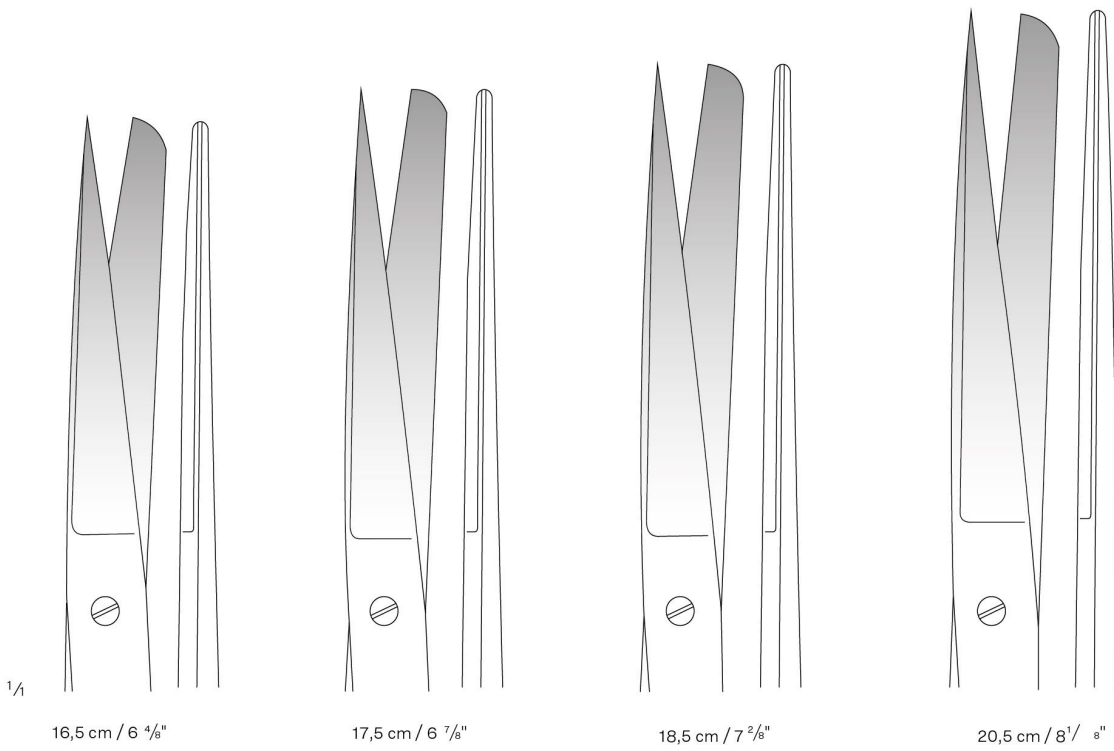

04



## Operating Scissors

Chirurgische Scheren  
Tijeras quirúrgicas  
Ciseaux chirurgicaux  
Forbici per chirurgia



Size	Standard	TC Gold
12 cm / 4 <sup>9</sup> / <sub>8</sub> "	<b>V02-105-12</b>	
13 cm / 5 <sup>1</sup> / <sub>8</sub> "	<b>V02-105-13</b>	
14,5 cm / 5 <sup>6</sup> / <sub>8</sub> "	<b>V02-105-14</b>	<b>V02-106-14</b>
15,5 cm / 6 <sup>1</sup> / <sub>8</sub> "	<b>V02-105-15</b>	
16,5 cm / 6 <sup>4</sup> / <sub>8</sub> "	<b>V02-105-16</b>	

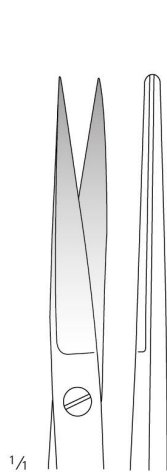

12 cm / 4 <sup>9</sup>/<sub>8</sub>"

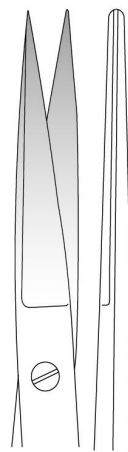

13 cm / 5 <sup>1</sup>/<sub>8</sub>"

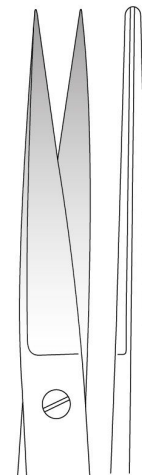

14,5 cm / 5 <sup>6</sup>/<sub>8</sub>"

## Operating Scissors

Chirurgische Scheren  
Tijeras quirúrgicas  
Ciseaux chirurgicaux  
Forbici per chirurgia

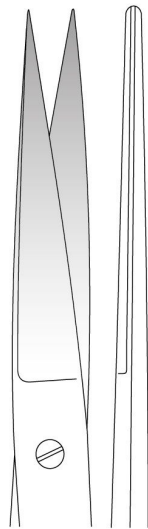

15,5 cm / 6 1/8"

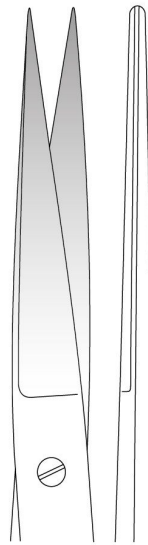

16,5 cm / 6 5/8"





## Operating Scissors

Chirurgische Scheren  
Tijeras quirúrgicas  
Ciseaux chirurgicaux  
Forbici per chirurgia



Size	Standard	TC Gold
12 cm / 4 <sup>9</sup> / <sub>8</sub> "	<b>V02-107-12</b>	
13 cm / 5 <sup>1</sup> / <sub>8</sub> "	<b>V02-107-13</b>	
14,5 cm / 5 <sup>6</sup> / <sub>8</sub> "	<b>V02-107-14</b>	<b>V02-108-14</b>
15,5 cm / 6 <sup>1</sup> / <sub>8</sub> "	<b>V02-107-15</b>	
16,5 cm / 6 <sup>4</sup> / <sub>8</sub> "	<b>V02-107-16</b>	
17,5 cm / 6 <sup>7</sup> / <sub>8</sub> "	<b>V02-107-17</b>	
18,5 cm / 7 <sup>2</sup> / <sub>8</sub> "	<b>V02-107-18</b>	
20,5 cm / 8 <sup>1</sup> / <sub>8</sub> "	<b>V02-107-20</b>	

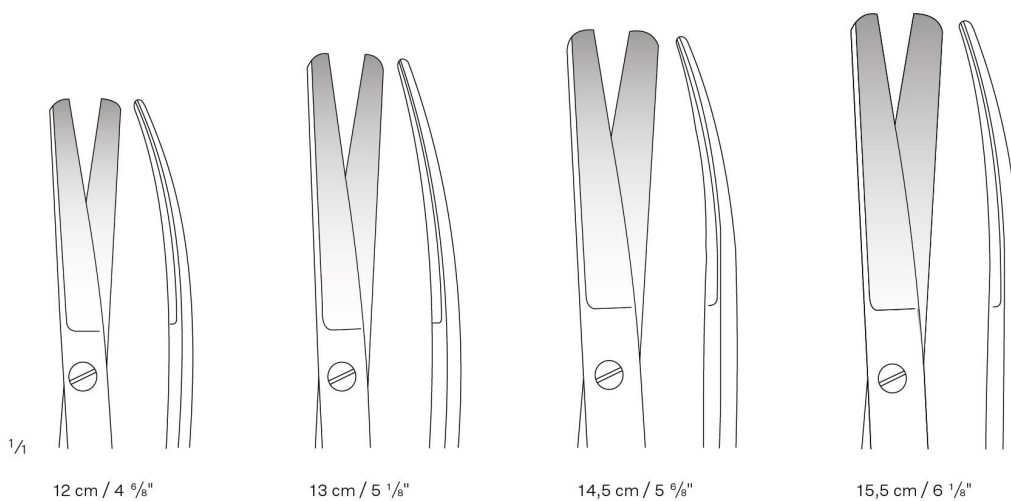

## Operating Scissors

Chirurgische Scheren  
Tijeras quirúrgicas  
Ciseaux chirurgicaux  
Forbici per chirurgia

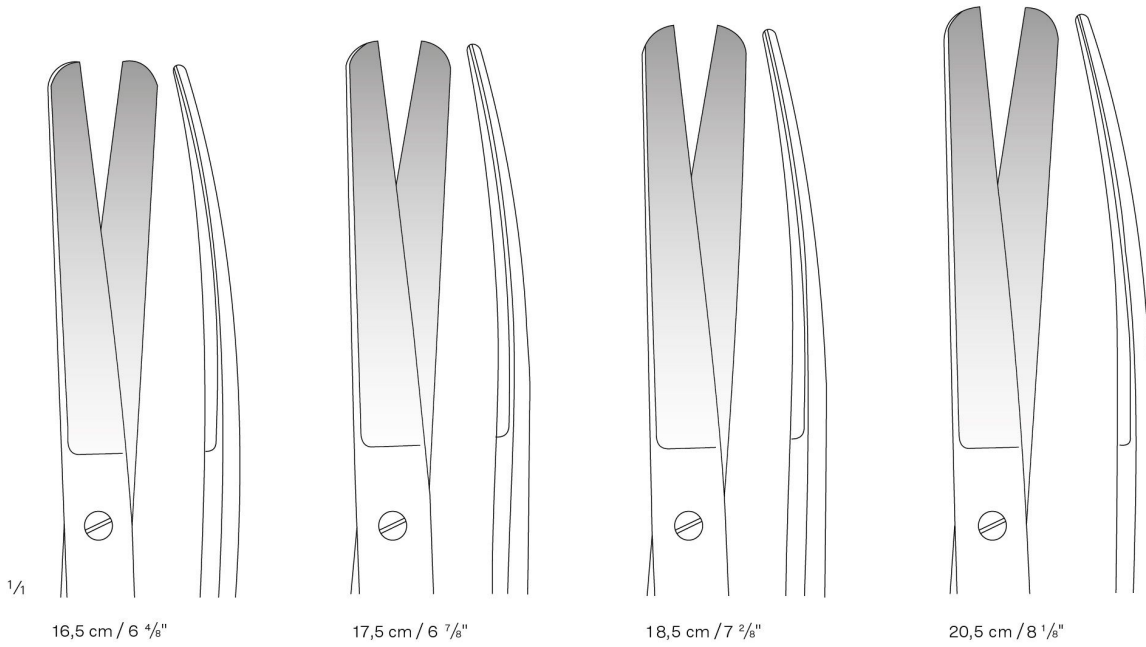

1/1

16,5 cm / 6 1/2"

17,5 cm / 6 7/8"

18,5 cm / 7 1/2"

20,5 cm / 8 1/8"



## Operating Scissors

Chirurgische Scheren  
Tijeras quirúrgicas  
Ciseaux chirurgicaux  
Forbici per chirurgia



Size	Standard	TC Gold	Super Cut
12 cm / 4 <sup>9</sup> / <sub>8</sub> "	<b>V02-109-12</b>		
13 cm / 5 <sup>1</sup> / <sub>8</sub> "	<b>V02-109-13</b>		
14,5 cm / 5 <sup>9</sup> / <sub>8</sub> "	<b>V02-109-14</b>	<b>V02-110-14</b>	<b>V02-111-14</b>
15,5 cm / 6 <sup>1</sup> / <sub>8</sub> "	<b>V02-109-15</b>		
16,5 cm / 6 <sup>4</sup> / <sub>8</sub> "	<b>V02-109-16</b>		
17,5 cm / 6 <sup>7</sup> / <sub>8</sub> "	<b>V02-109-17</b>		
18,5 cm / 7 <sup>2</sup> / <sub>8</sub> "	<b>V02-109-18</b>		
20,5 cm / 8 <sup>1</sup> / <sub>8</sub> "	<b>V02-109-20</b>		

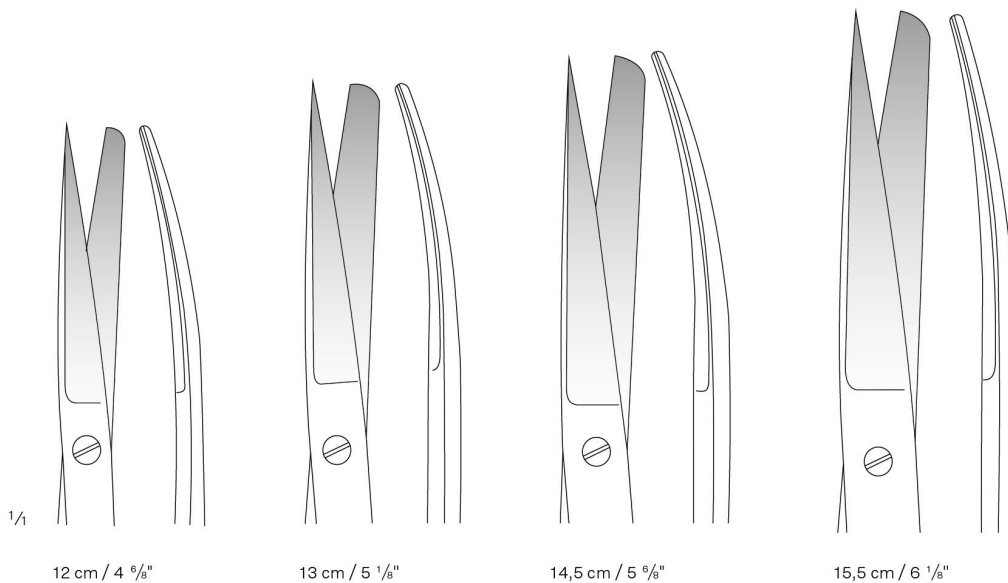

## Operating Scissors

Chirurgische Scheren  
Tijeras quirúrgicas  
Ciseaux chirurgicaux  
Forbici per chirurgia

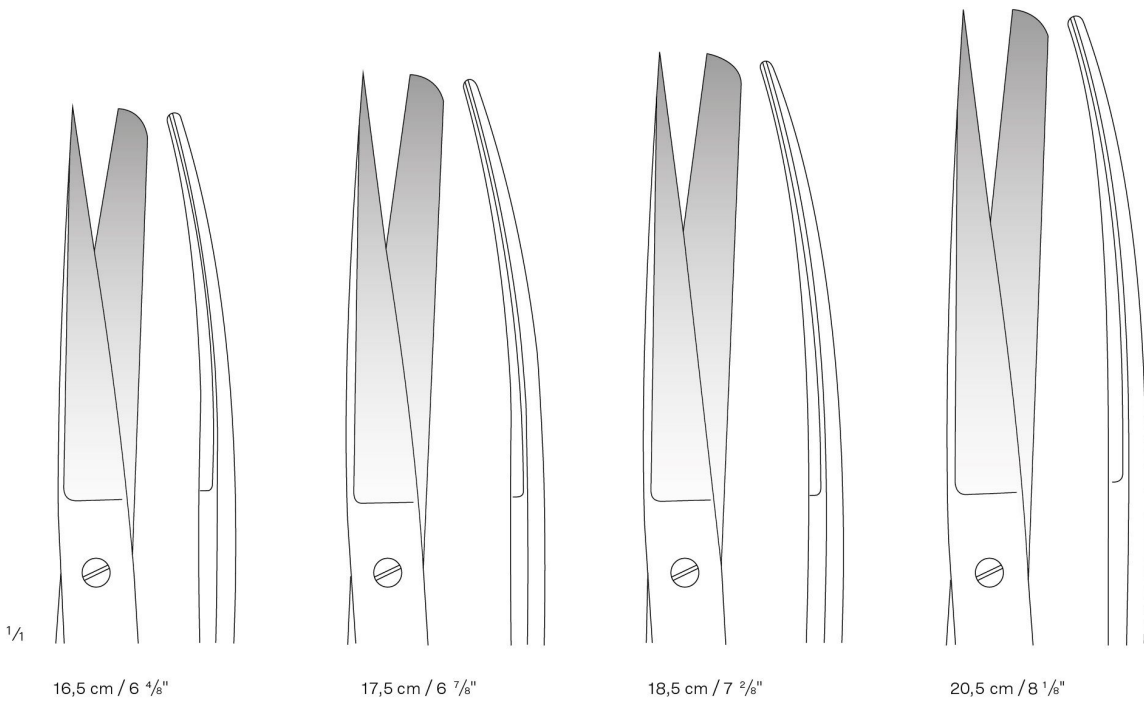

## Operating Scissors

Chirurgische Scheren  
Tijeras quirúrgicas  
Ciseaux chirurgicaux  
Forbici per chirurgia



Size	Standard	TC Gold
12 cm / 4 <sup>9</sup> / <sub>8</sub> "	<b>V02-112-12</b>	
13 cm / 5 <sup>1</sup> / <sub>8</sub> "	<b>V02-112-13</b>	
14,5 cm / 5 <sup>9</sup> / <sub>8</sub> "	<b>V02-112-14</b>	<b>V02-113-14</b>
15,5 cm / 6 <sup>1</sup> / <sub>8</sub> "	<b>V02-112-15</b>	
16,5 cm / 6 <sup>4</sup> / <sub>8</sub> "	<b>V02-112-16</b>	

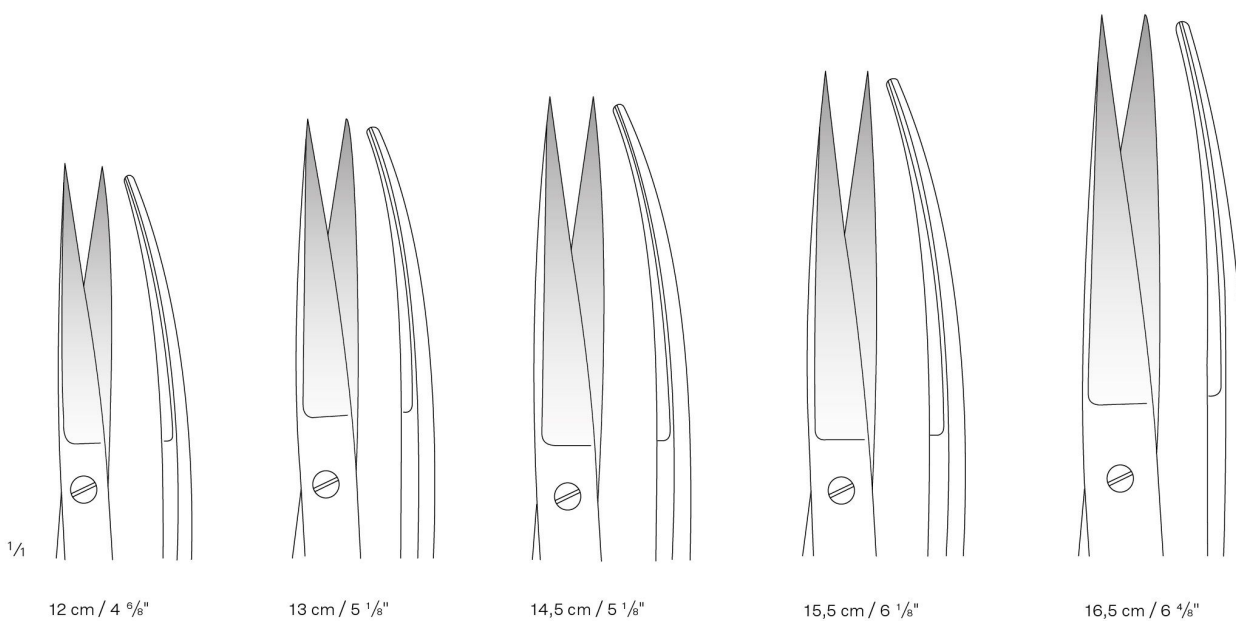

12 cm / 4 <sup>9</sup>/<sub>8</sub>"

13 cm / 5 <sup>1</sup>/<sub>8</sub>"

14,5 cm / 5 <sup>9</sup>/<sub>8</sub>"

15,5 cm / 6 <sup>1</sup>/<sub>8</sub>"

16,5 cm / 6 <sup>4</sup>/<sub>8</sub>"

## Operating Scissors

Chirurgische Scheren  
Tijeras quirúrgicas  
Ciseaux chirurgicaux  
Forbici per chirurgia

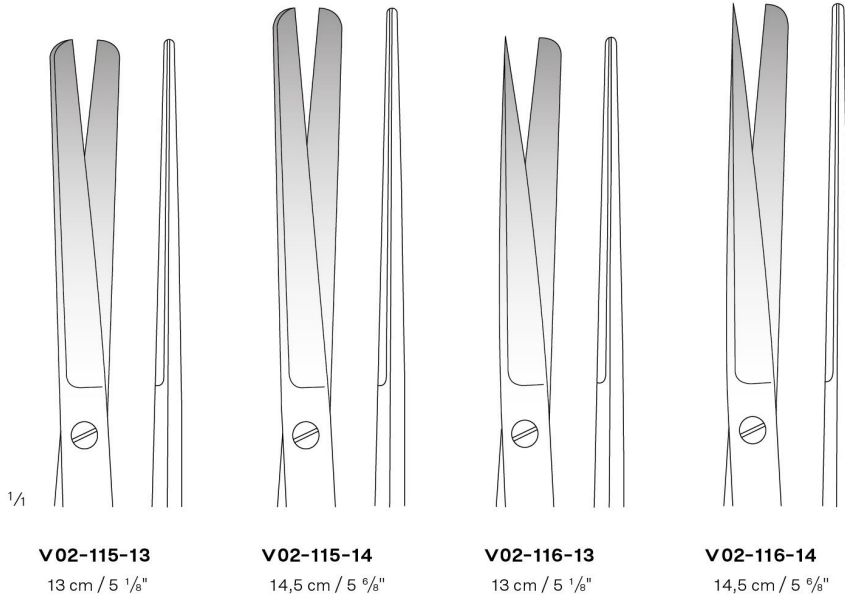

**V02-115-13**  
13 cm / 5 1/8"

**V02-115-14**  
14,5 cm / 5 9/16"

**V02-116-13**  
13 cm / 5 1/8"

**V02-116-14**  
14,5 cm / 5 9/16"



**V02-115-14**  
to  
**V02-117-14**

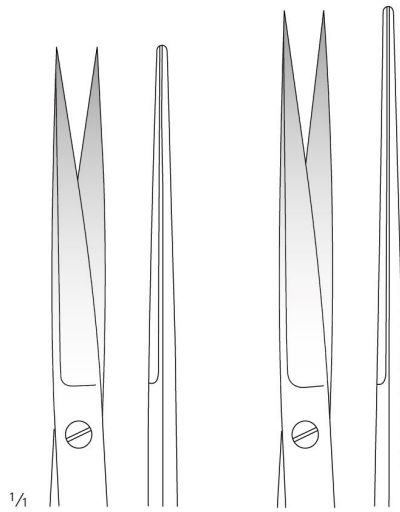

**V02-117-13**  
13 cm / 5 1/8"

**V02-117-14**  
14,5 cm / 5 9/16"



## Operating Scissors

Chirurgische Scheren  
Tijeras quirúrgicas  
Ciseaux chirurgicaux  
Forbici per chirurgia

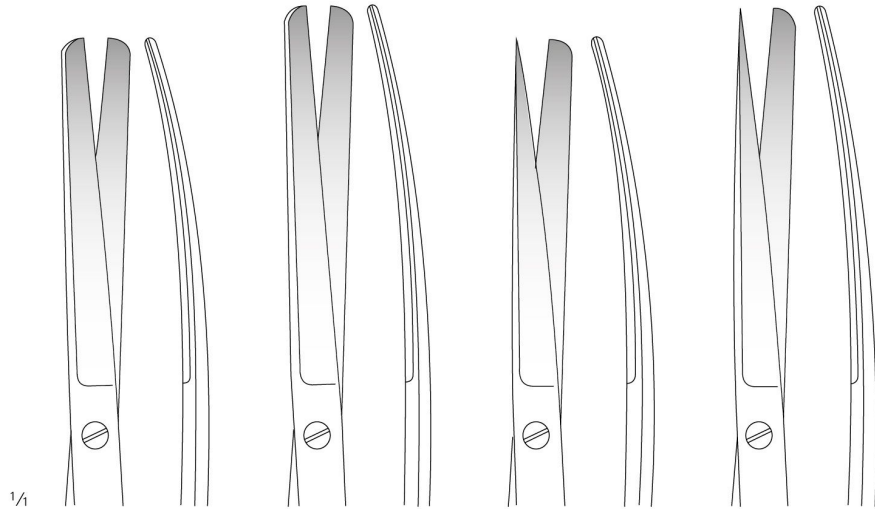

**V02-118-13**  
13 cm / 5 1/8"

**V02-118-14**  
14,5 cm / 5 9/16"

**V02-119-13**  
13 cm / 5 1/8"

**V02-119-14**  
14,5 cm / 5 9/16"



**V02-118-14**  
to  
**V02-120-14**

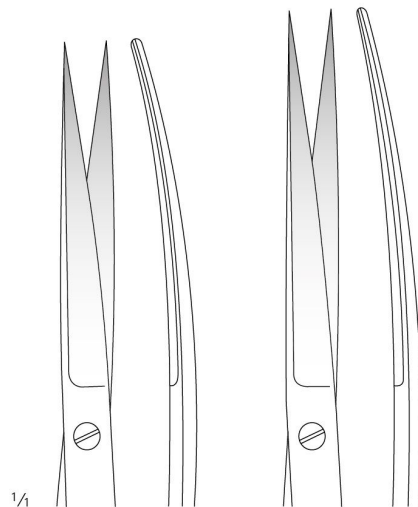

**V02-120-13**  
13 cm / 5 1/8"

**V02-120-14**  
14,5 cm / 5 9/16"

## Operating Scissors

Chirurgische Scheren  
Tijeras quirúrgicas  
Ciseaux chirurgicaux  
Forbici per chirurgia

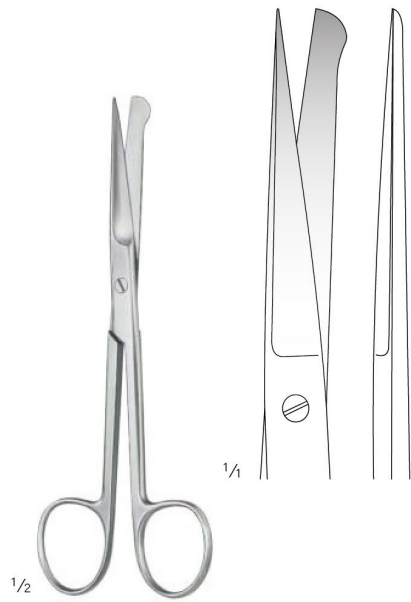

### V02-121-14

14,5 cm / 5 9/16"

Inzisionsschere  
Incision Scissors  
Tijera para incisiones  
Ciseaux à incision  
Forbici per incisione



**V02-122-14**  
14,5 cm / 5 9/16"

**V02-123-14**  
14 cm / 5 4/8"

**Deaver**  
V02-122-14  
to  
V02-123-14

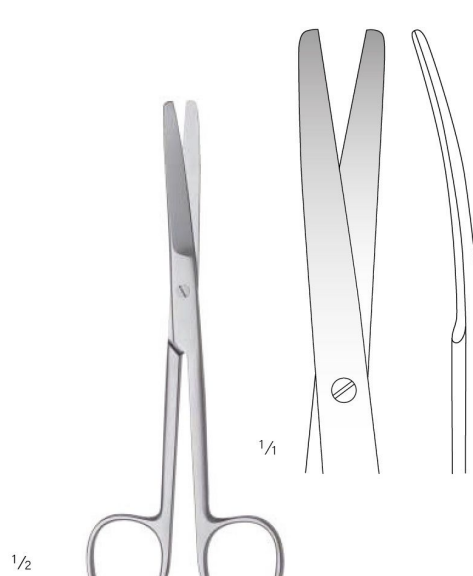

**Deaver**  
V02-124-14  
14,5 cm / 5 9/16"





**Dissecting Scissors**

Präparierscheren  
Tijeras de disección  
Ciseaux à dissection  
Forbici per dissezione



Mayo	Standard	TC Gold	Super Cut
14,5 cm / 5 9/16"	V02-125-14	V02-126-14	V02-127-14
15 cm / 5 7/8"	V02-125-15		
17 cm / 6 9/16"	V02-125-17	V02-126-17	V02-127-17
23,5 cm / 9 2/8"	V02-125-23	V02-126-23	V02-127-23

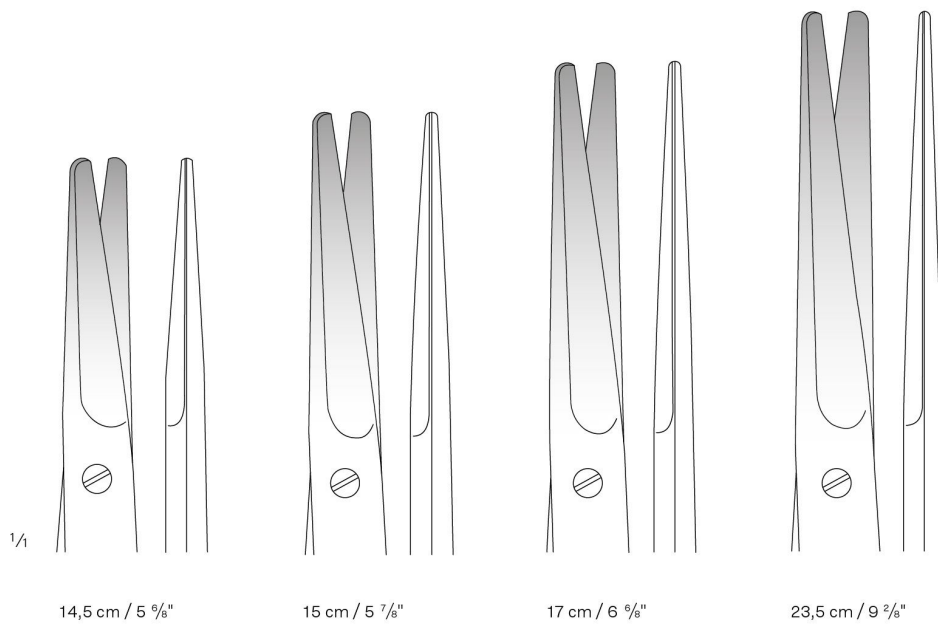

14,5 cm / 5 9/16"

15 cm / 5 7/8"

17 cm / 6 9/16"

23,5 cm / 9 2/8"

**Dissecting Scissors**

Präparierscheren  
Tijeras de disección  
Ciseaux à dissection  
Forbici per dissezione



Mayo	Standard	TC Gold	Super Cut
14,5 cm / 5 9/16"	<b>V02-128-14</b>	<b>V02-129-14</b>	<b>V02-130-14</b>
15 cm / 5 7/8"	<b>V02-128-15</b>		
17 cm / 6 9/16"	<b>V02-128-17</b>	<b>V02-129-17</b>	<b>V02-130-17</b>
23,5 cm / 9 2/8"	<b>V02-128-23</b>	<b>V02-129-23</b>	<b>V02-130-23</b>

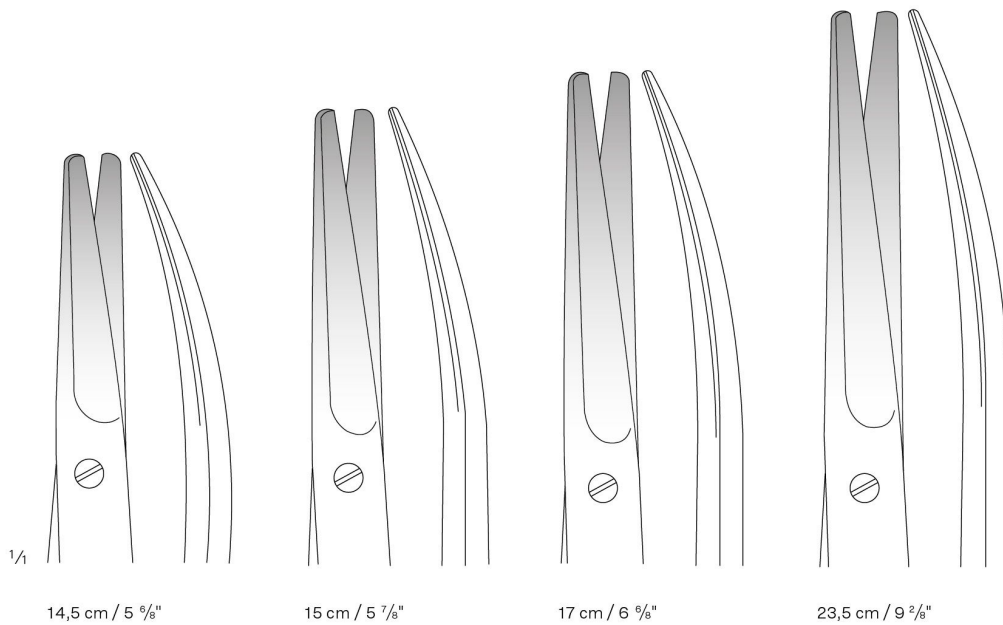

## Dissecting Scissors

Präparierscheren  
Tijeras de disección  
Ciseaux à dissection  
Forbici per dissezione



Mayo-Style	Standard	TC Gold	Super Cut
15 cm / 5 7/8"	<b>V02-131-15</b>	<b>V02-132-15</b>	<b>V02-133-15</b>
17 cm / 6 5/8"	<b>V02-131-17</b>	<b>V02-132-17</b>	<b>V02-133-17</b>

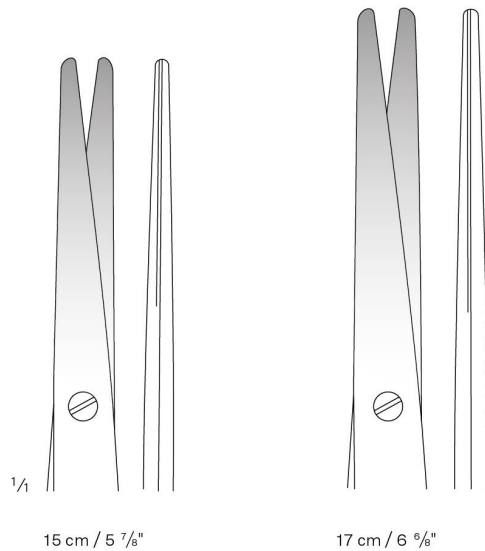

**Dissecting Scissors**

Präparierscheren  
Tijeras de disección  
Ciseaux à dissection  
Forbici per dissezione



Mayo-Style	Standard	TC Gold	Super Cut
15 cm / 5 7/8"	V02-134-15	V02-135-15	V02-136-15
17 cm / 6 5/8"	V02-134-17	V02-135-17	V02-136-17

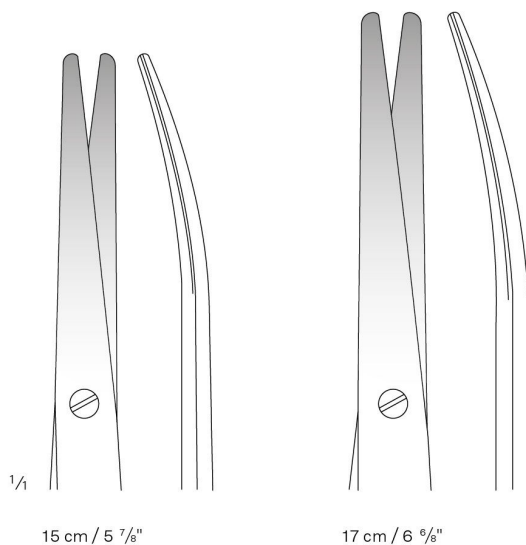

**Dissecting Scissors**

Präparierscheren  
Tijeras de disección  
Ciseaux à dissection  
Forbici per dissezione

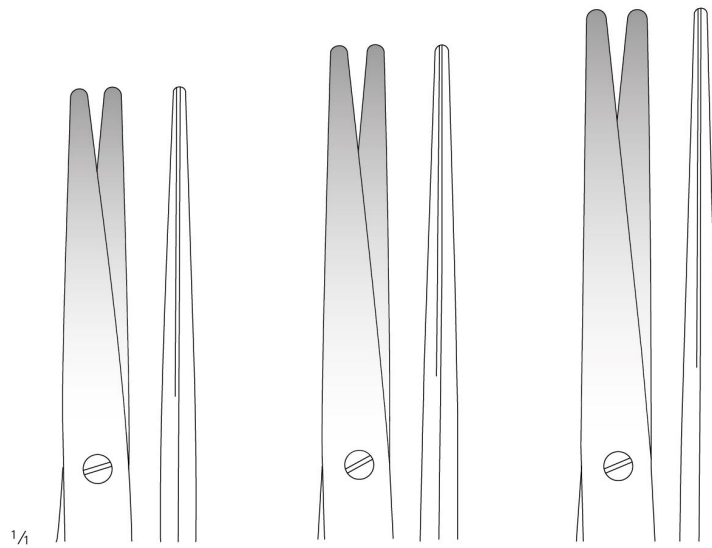

**V02-137-16**  
16 cm / 6 <sup>2</sup>/<sub>6</sub>"

**V02-137-19**  
19,5 cm / 7 <sup>5</sup>/<sub>6</sub>"

**V02-137-21**  
21,5 cm / 8 <sup>4</sup>/<sub>6</sub>"



1/2

**Mayo-Stillie**  
**V02-137-16**  
to  
**V02-138-21**

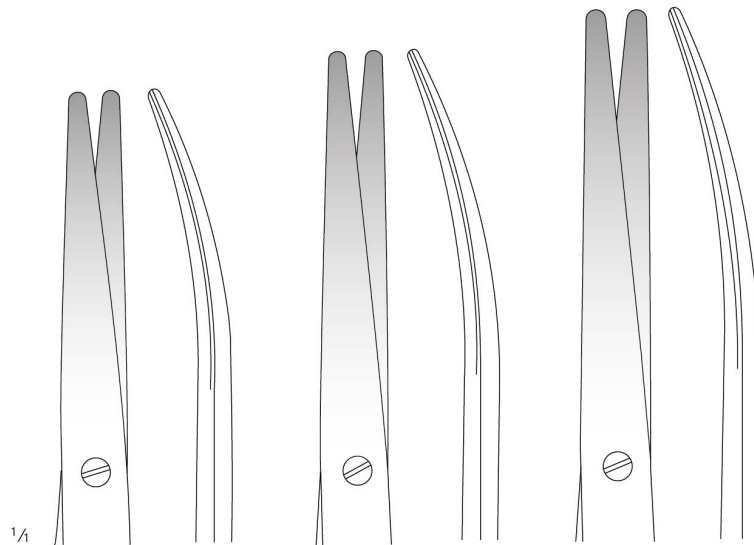

**V02-138-16**  
16 cm / 6 <sup>2</sup>/<sub>6</sub>"

**V02-138-19**  
19,5 cm / 7 <sup>5</sup>/<sub>6</sub>"

**V02-138-21**  
21,5 cm / 8 <sup>4</sup>/<sub>6</sub>"

**Dissecting Scissors**

Präparierscheren  
Tijeras de disección  
Ciseaux à dissection  
Forbici per dissezione



**V02-139-23**  
23 cm / 9"



**V02-141-16**



**Mayo-Harrington**  
V02-139-23  
to  
V02-140-28



**V02-140-23**  
23 cm / 9"



**V02-140-28**  
28 cm / 11"



**Mayo-Noble**  
V02-141-16  
to  
V02-142-16  
16,5 cm / 6 1/8"



**V02-142-16**

**Gynecological Scissors**  
 Gynäkologische Scheren  
 Tijeras para ginecología  
 Ciseaux à gynécologie  
 Forbici per ginecologia



Sims	Standard	TC Gold
20 cm / 7 7/8"	<b>V02-143-20</b>	
23 cm / 9"	<b>V02-143-23</b>	<b>V02-144-23</b>

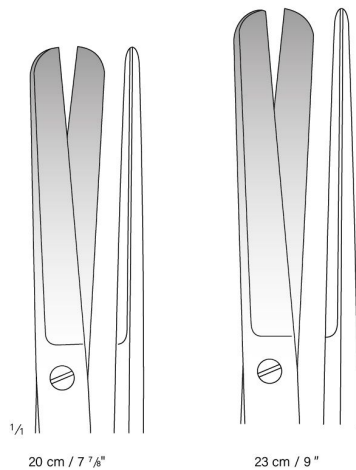

**Gynecological Scissors**  
 Gynäkologische Scheren  
 Tijeras para ginecología  
 Ciseaux à gynécologie  
 Forbici per ginecologia



Sims	Standard	TC Gold	Super Cut TC	TCC BlackLine
20 cm / 7 7/8"	V02-145-20		V02-147-20	V02-148-20
23 cm / 9"	V02-145-23	V02-146-23	V02-147-23	V02-148-23

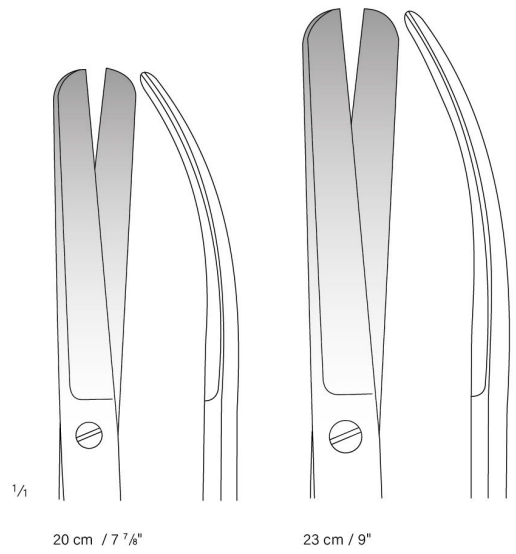



## Operating Scissors

Chirurgische Scheren  
 Tijeras quirúrgicas  
 Ciseaux chirurgicaux  
 Forbici per chirurgia



Kelly	Standard	TC Gold	Super Cut
16 cm / 6 2/8"	V02-149-16	V02-150-16	V02-151-16

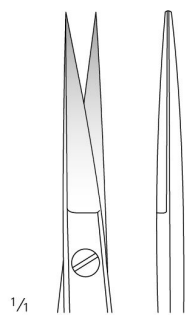

## Operating Scissors

Chirurgische Scheren  
 Tijeras quirúrgicas  
 Ciseaux chirurgicaux  
 Forbici per chirurgia



Kelly	Standard	TC Gold	Super Cut
16 cm / 6 5/8"	V02-152-16	V02-153-16	V02-154-16

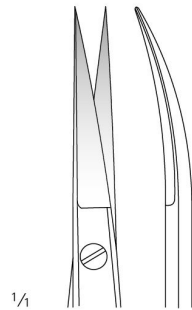

**Gynecological Scissors**  
Gynäkologische Scheren  
Tijeras para ginecología  
Ciseaux à gynécologie  
Forbici per ginecologia

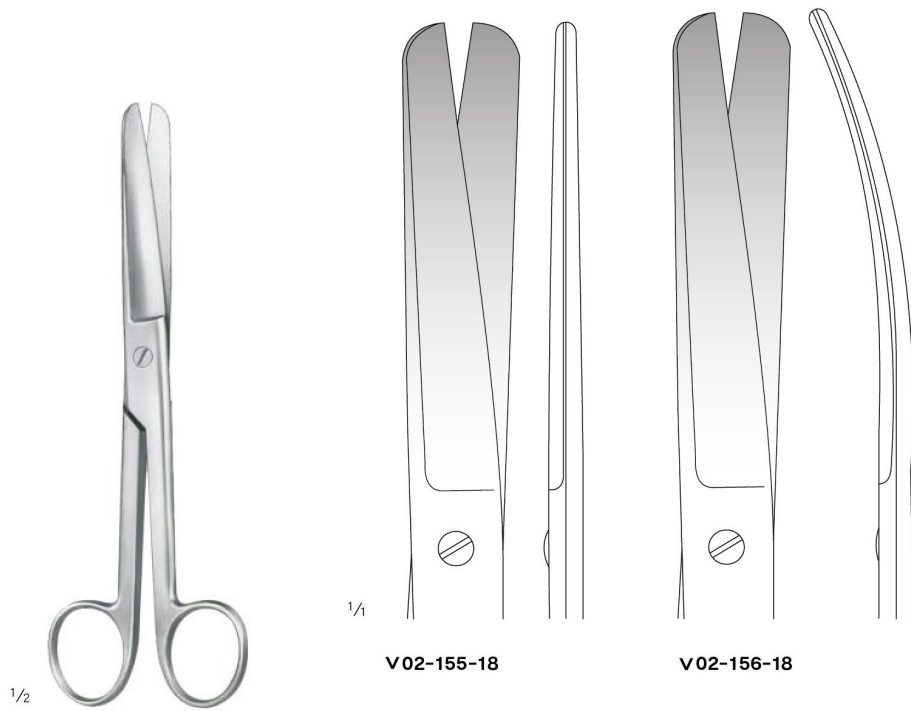

**Doyen**

**V02-155-18**

to

**V02-156-18**

18,5 cm / 7 <sup>2</sup>/<sub>8</sub>"

**Gynecological Scissors**  
Gynäkologische Scheren  
Tijeras para ginecología  
Ciseaux à gynécologie  
Forbici per ginecologia



**Sims-Siebold**  
**V02-157-24**  
24,5 cm / 9 5/8"

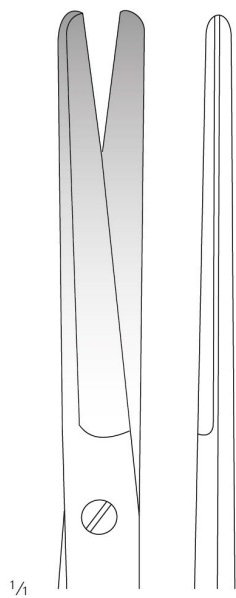

**Sims-Siebold**  
**V02-158-24**  
24,5 cm / 9 5/8"

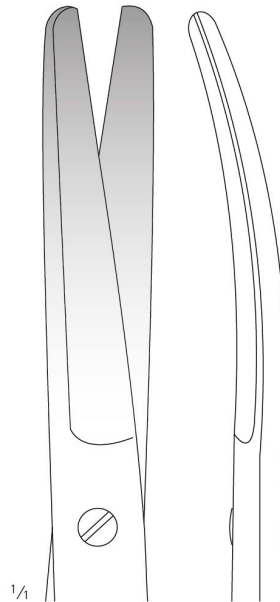

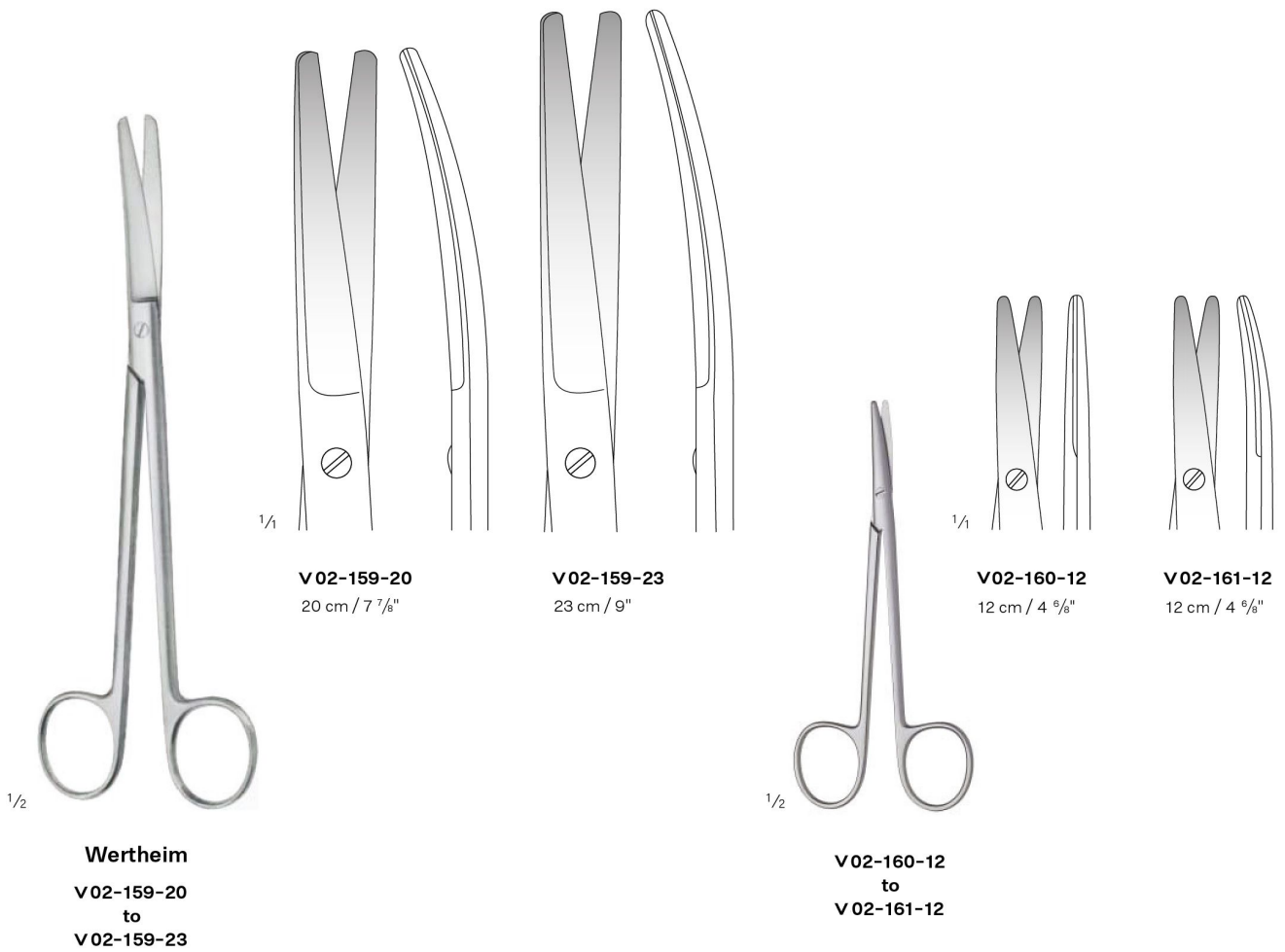

**Dissecting Scissors**  
 Präparierscheren  
 Tijeras de disección  
 Ciseaux à dissection  
 Forbici per dissezione



02



Metzenbaum	Standard	TC Gold	Super Cut
11,5 cm / 4 5/8"	V02-162-11	V02-163-11	V02-164-11

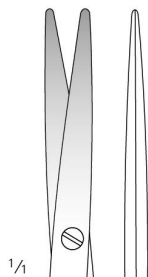

**Dissecting Scissors**  
 Präparierscheren  
 Tijeras de disección  
 Ciseaux à dissection  
 Forbici per dissezione



Metzenbaum	Standard	TC Gold	Super Cut
11,5 cm / 4 4/8"	V02-165-11	V02-166-11	V02-167-11

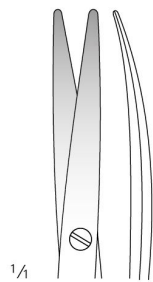

**Dissecting Scissors**  
 Präparierscheren  
 Tijeras de disección  
 Ciseaux à dissection  
 Forbici per dissezione



Metzenbaum	Super Cut TC	TCC BlackLine
11,5 cm / 4 5/8"	V02-168-11	V02-169-11





**Dissecting Scissors**  
 Präparierscheren  
 Tijeras de disección  
 Ciseaux à dissection  
 Forbici per dissezione



Metzenbaum	Standard	TC Gold	Super Cut
14,5 cm / 5 7/8"	V02-170-14	V02-171-14	V02-172-14



**Dissecting Scissors**  
 Präparierscheren  
 Tijeras de disección  
 Ciseaux à dissection  
 Forbici per dissezione



02



Metzenbaum	Standard	TC Gold	Super Cut
14,5 cm / 5 7/8"	V02-173-14	V02-174-14	V02-175-14

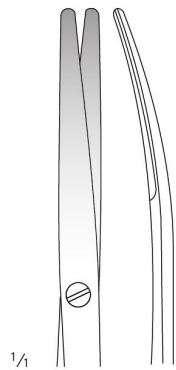



V02-176-14



V02-177-14



V02-178-14



V02-179-14

**Metzenbaum**

V02-176-14

to

V02-179-14

14,5 cm / 5 7/8"



V02-180-15

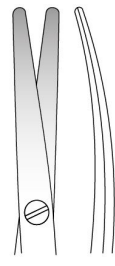

V02-181-15



V02-182-18  
 18 cm / 7 1/8"

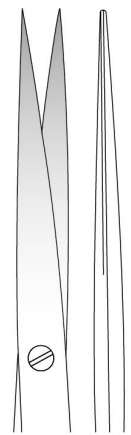

V02-182-20  
 20,5 cm / 8 1/8"

**Metzenbaum**

V02-180-15

to

V02-181-15

15,5 cm / 6 1/8"

**Metzenbaum-Nelson**

V02-182-18

to

V02-182-20

**Dissecting Scissors**  
 Präparierscheren  
 Tijeras de disección  
 Ciseaux à dissection  
 Forbici per dissezione



Metzenbaum	Standard	TC Gold	Super Cut
18 cm / 7 1/8"	<b>V02-183-18</b>	<b>V02-184-18</b>	<b>V02-185-18</b>
20,5 cm / 8 1/8"	<b>V02-183-20</b>	<b>V02-184-20</b>	<b>V02-185-20</b>
23 cm / 9"	<b>V02-183-23</b>	<b>V02-184-23</b>	<b>V02-185-23</b>
26 cm / 10 2/8"	<b>V02-183-26</b>	<b>V02-184-26</b>	<b>V02-185-26</b>
28,5 cm / 11 2/8"	<b>V02-183-28</b>	<b>V02-184-28</b>	<b>V02-185-28</b>
31 cm / 12 2/8"	<b>V02-183-31</b>	<b>V02-184-31</b>	<b>V02-185-31</b>

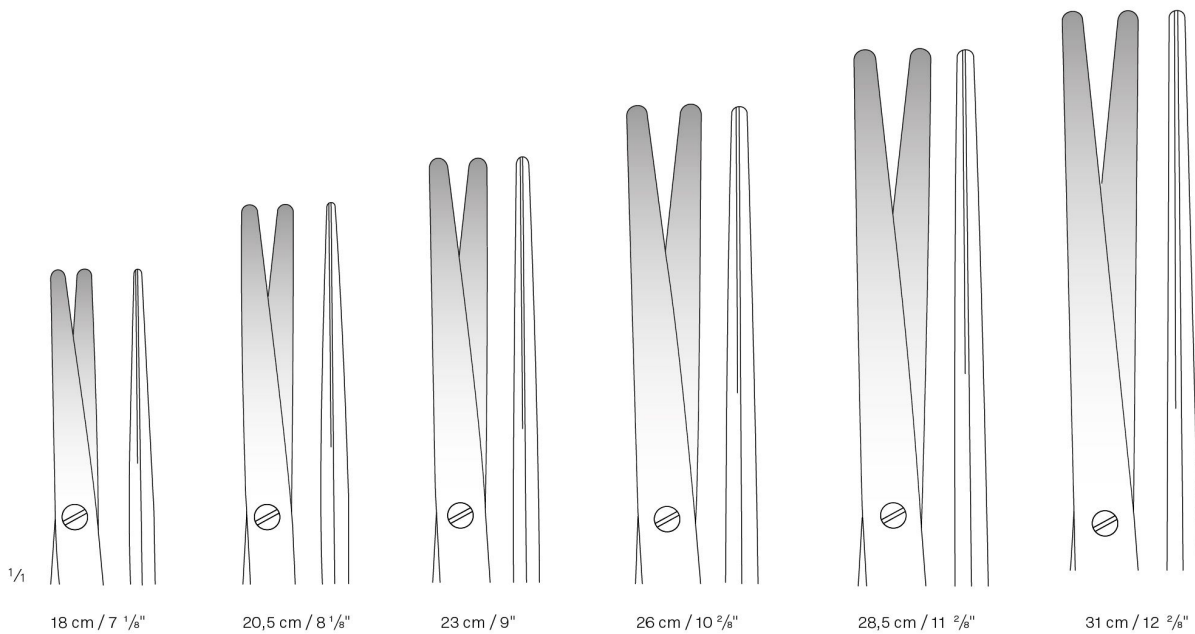

**Dissecting Scissors**  
 Präparierscheren  
 Tijeras de disección  
 Ciseaux à dissection  
 Forbici per dissezione



Metzenbaum	Standard	TC Gold	Super Cut
18 cm / 7 1/8"	V02-186-18	V02-187-18	V02-188-18
20,5 cm / 8 1/8"	V02-186-20	V02-187-20	V02-188-20
23 cm / 9"	V02-186-23	V02-187-23	V02-188-23
26 cm / 10 2/8"	V02-186-26	V02-187-26	V02-188-26
28,5 cm / 11 2/8"	V02-186-28	V02-187-28	V02-188-28
31 cm / 12 2/8"	V02-186-31	V02-187-31	V02-188-31

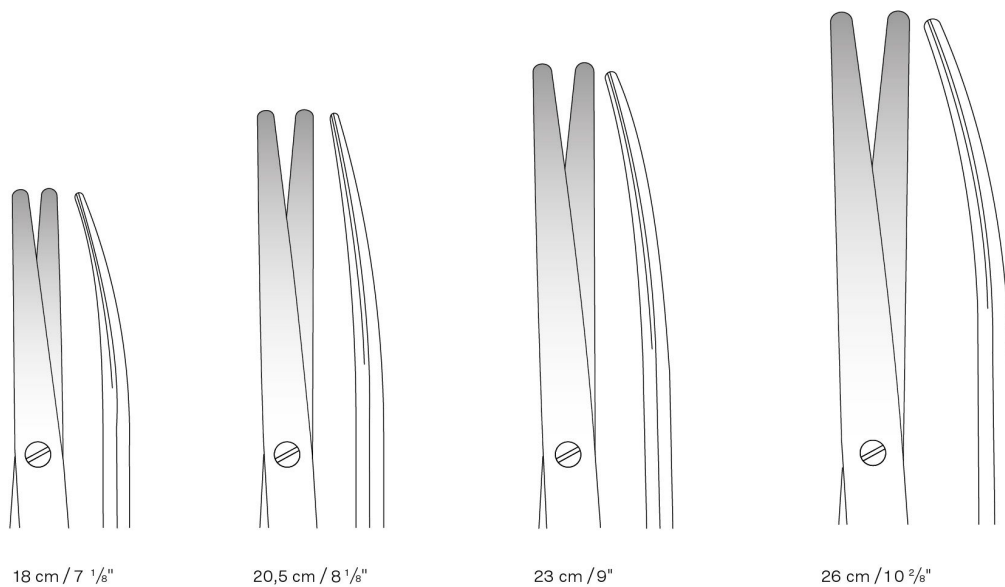

18 cm / 7 1/8"

20,5 cm / 8 1/8"

23 cm / 9"

26 cm / 10 2/8"

**Dissecting Scissors**  
 Präparierscheren  
 Tijeras de disección  
 Ciseaux à dissection  
 Forbici per dissezione



Metzenbaum	Super Cut TC	TCC BlackLine
18 cm / 7 1/8"	V02-189-18	V02-190-18
20,5 cm / 8 1/8"	V02-189-20	V02-190-20
23 cm / 9"	V02-189-23	V02-190-23
26 cm / 10 2/8"	V02-189-26	V02-190-26
31 cm / 12 2/8"	V02-189-31	V02-190-31

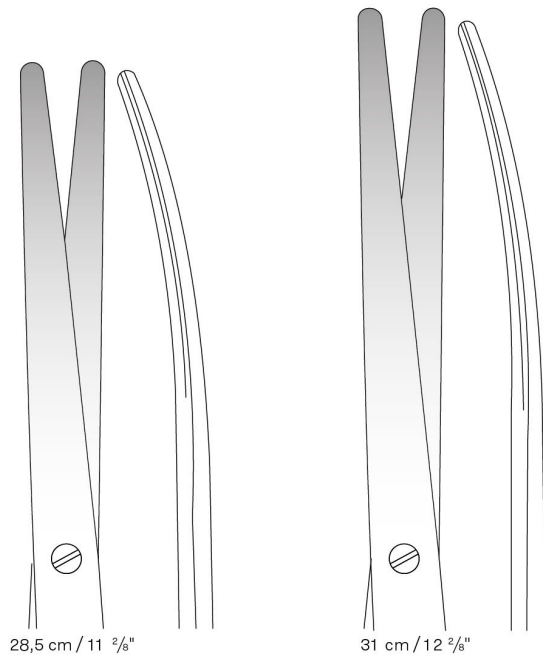



**Metzenbaum**  
**V02-191-14**  
 to  
**V02-192-14**

14,5 cm / 5 7/8"  
 eine Schneide gezahnt  
 one toothed cutting edge  
 una hoja dentada  
 une lame dentelée  
 una lama dentata



**V02-193-15**  
 to  
**V02-194-15**

15,5 cm / 6 1/8"  
 Nerv-Präparierschere  
 Nerve Dissecting Scissors  
 Tijeras para disección de nervios  
 Ciseaux pour nerfs  
 Forbici per nervi



**Dissecting Scissors**  
 Präparierscheren  
 Tijeras de disección  
 Ciseaux à dissection  
 Forbici per dissezione

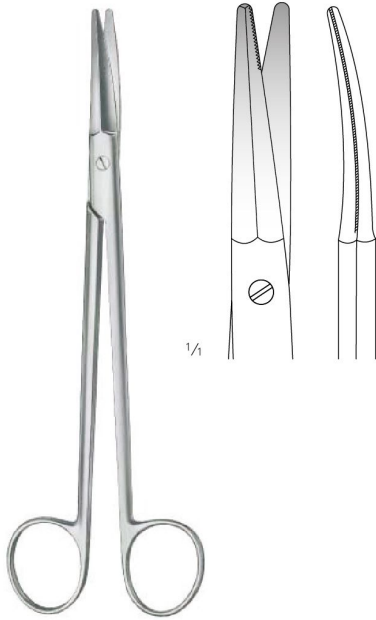
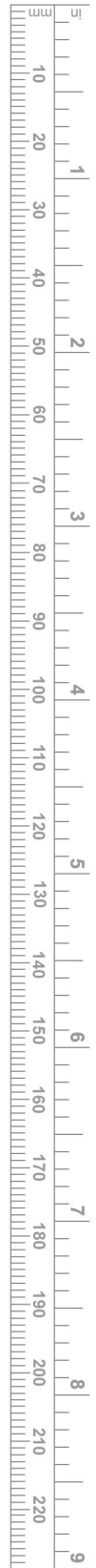

**Kaye**

**V02-195-18**

18,5 cm / 7 2/8"

beide Schneiden gezahnt  
 both cutting edges serrated  
 ambos filos dentados  
 deux lames dentées  
 entrambe le lame dentate



**Gorney**

**V02-196-12**

to

**V02-199-17**

beide Schneiden gezahnt  
 both cutting edges serrated  
 ambos filos dentados  
 deux lames dentées  
 entrambe le lame dentate

**V02-196-12**  
 12,5 cm / 4 7/8"

**V02-197-19**  
 19,5 cm / 7 5/8"

**V02-198-19**  
 19,5 cm / 7 5/8"

**V02-199-17**  
 17 cm / 6 5/8"



**Dissecting Scissors**  
 Präparierscheren  
 Tijeras de disección  
 Ciseaux à dissection  
 Forbici per dissezione



Lexer	Standard	TC Gold	Super Cut
16 cm / 6 2/8"	V02-200-16	V02-201-16	V02-202-16

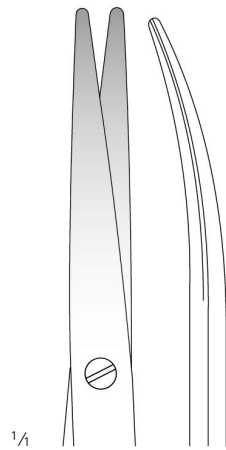

**Dissecting Scissors**  
 Präparierscheren  
 Tijeras de disección  
 Ciseaux à dissection  
 Forbici per dissezione



Lexer	Super Cut TC	TCC BlackLine
16 cm / 6 2/8"	V02-203-16	V02-204-16



**Dissecting Scissors**  
 Präparierscheren  
 Tijeras de disección  
 Ciseaux à dissection  
 Forbici per dissezione



Lexer	Standard	TC Gold	Super Cut
16 cm / 6 2/8"	V02-205-16	V02-20616	V02-207-16

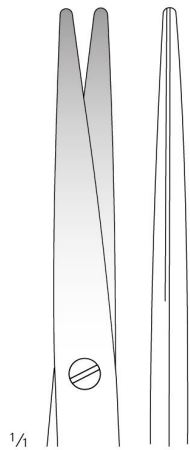

**Dissecting Scissors**  
 Präparierscheren  
 Tijeras de disección  
 Ciseaux à dissection  
 Forbici per dissezione



Hohenfellner	Standard	TC Gold
18 cm / 7 1/8"	V 02-208-18	V 02-209-18
21 cm / 8 2/8"	V 02-208-21	V 02-209-21
24 cm / 9 4/8"	V 02-208-24	V 02-209-24

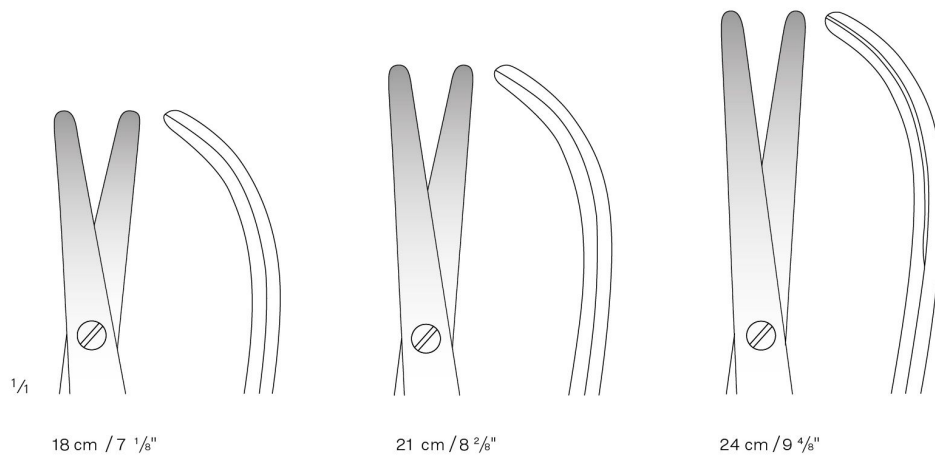

18 cm / 7 1/8"

21 cm / 8 2/8"

24 cm / 9 4/8"



**Dissecting Scissors**  
 Präparierscheren  
 Tijeras de disección  
 Ciseaux à dissection  
 Forbici per dissezione



DeBakey	Standard	TC Gold
17,5 cm / 6 <sup>7</sup> / <sub>8</sub> "	<b>V02-210-17</b>	<b>V02-211-17</b>
20 cm / 7 <sup>7</sup> / <sub>8</sub> "	<b>V02-210-20</b>	<b>V02-211-20</b>

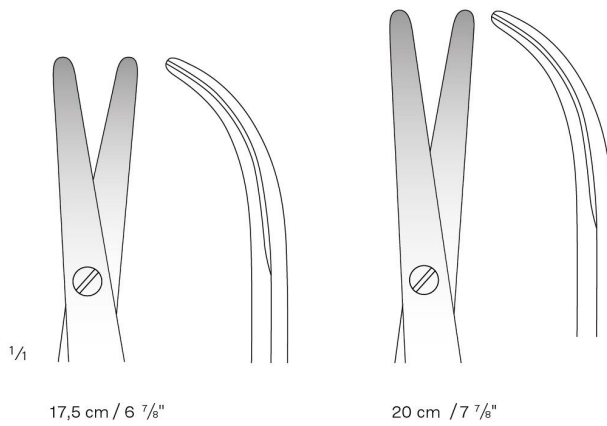

**Dissecting Scissors**  
 Präparierscheren  
 Tijeras de disección  
 Ciseaux à dissection  
 Forbici per dissezione



**Cinelli**  
**V02-212-11**  
 11,5 cm / 4 5/8"



**Fomon**  
**V02-213-14**  
 14 cm / 5 4/8"



**Thorek**  
**V02-214-18**  
 18,5 cm / 7 3/8"

**Dissecting Scissors**  
 Präparierscheren  
 Tijeras de disección  
 Ciseaux à dissection  
 Forbici per dissezione

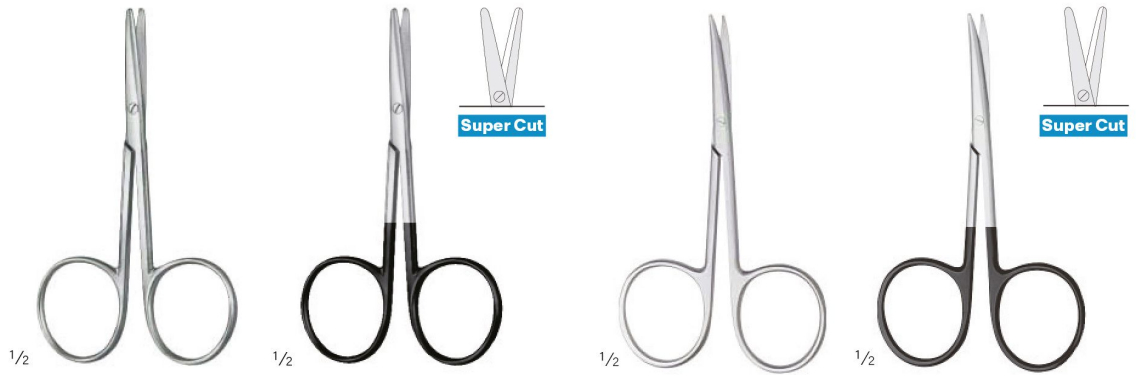

Lexer-Baby	Standard	Super Cut
10 cm / 3 7/8"	V02-215-10	V02-216-10

Standard	Super Cut
V02-217-10	V02-218-10

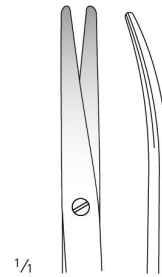
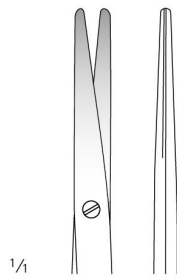

**Dissecting Scissors**  
 Präparierscheren  
 Tijeras de disección  
 Ciseaux à dissection  
 Forbici per dissezione

**FinoLine**

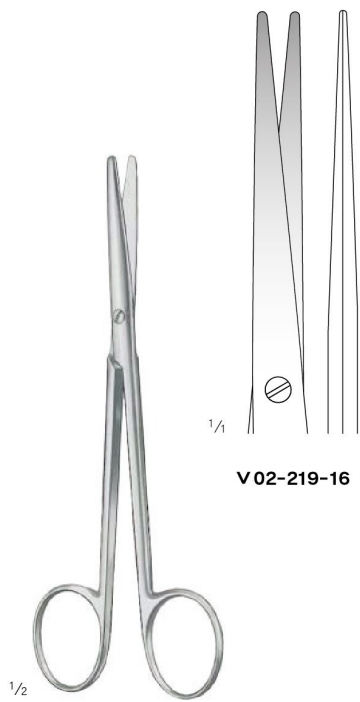

**V02-219-16**

**V02-220-16**

**Lexer-Fino**  
**V02-219-16**  
**V02-220-16**  
 16,5 cm / 6 5/8"  
 schlankes Modell  
 slender pattern  
 modelo delgado  
 modèle gracile  
 modello delicato



**V02-221-20**  
 20,5 cm / 8 1/8"

**V02-221-23**  
 23 cm / 9"

**Metzenbaum-Fino**  
**V02-221-20**  
**V02-221-23**  
 schlankes Modell  
 slender pattern  
 modelo delgado  
 modèle gracile  
 modello delicato





**Delicate Dissecting Scissors**

Feine Präparierscheren  
Tijeras finas de disección  
Ciseaux fins à dissection  
Forbici fini per dissezione



**FinoLine**



Metzenbaum-Fino	Standard	TC Gold
14,5 cm / 5 6/8"	V02-222-14	V02-223-14

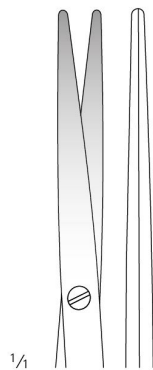

1/1  
schlankes Modell  
slender pattern  
modelo delgado  
modèle gracile  
modello delicato

**Delicate Dissecting Scissors**

Feine Präparierscheren  
Tijeras finas de disección  
Ciseaux fins à dissection  
Forbici fini per dissezione



**FinoLine**



Metzenbaum-Fino	Standard	TC Gold	Super Cut	Super Cut TC
14,5 cm / 5 9/16"	V02-224-14	V02-225-14	V02-226-14	V02-227-14

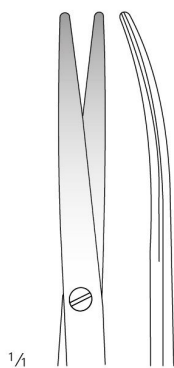

schlankes Modell  
slender pattern  
modelo delgado  
modèle gracile  
modello delicato

**Delicate Dissecting Scissors**

Feine Präparierscheren  
Tijeras finas de disección  
Ciseaux fins à dissection  
Forbici fini per dissezione



**FinoLine**



Metzenbaum Fino	Standard	TC Gold
14,5 cm / 5 7/8"	V02-228-14	V02-229-14

Standard	TC Gold
V02-230-14	V02-231-14

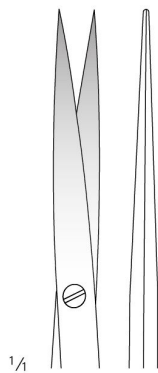

schlankes Modell  
slender pattern  
modelo delgado  
modèle gracile  
modello delicato

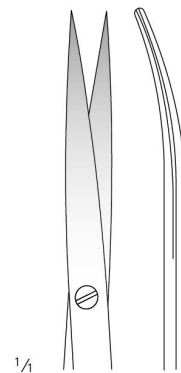

schlankes Modell  
slender pattern  
modelo delgado  
modèle gracile  
modello delicato



**Delicate Dissecting Scissors**

Feine Präparierscheren  
Tijeras finas de disección  
Ciseaux fins à dissection  
Forbici fini per dissezione



**FinoLine**



Metzenbaum Fino	Standard	TC Gold
	V02-232-18	V02-233-18



**Delicate Dissecting Scissors**

Feine Präparierscheren  
Tijeras finas de disección  
Ciseaux fins à dissection  
Forbici fini per dissezione



**FinoLine**



Metzenbaum Fino	Standard	TC Gold	Super Cut	Super Cut TC
18 cm / 7 1/8"	V02-234-18	V02-235-18	V02-236-18	V02-237-18
20,5 cm / 8 1/8"	V02-234-20	V02-235-20	V02-236-20	
23 cm / 9"	V02-234-23	V02-235-23	V02-236-23	

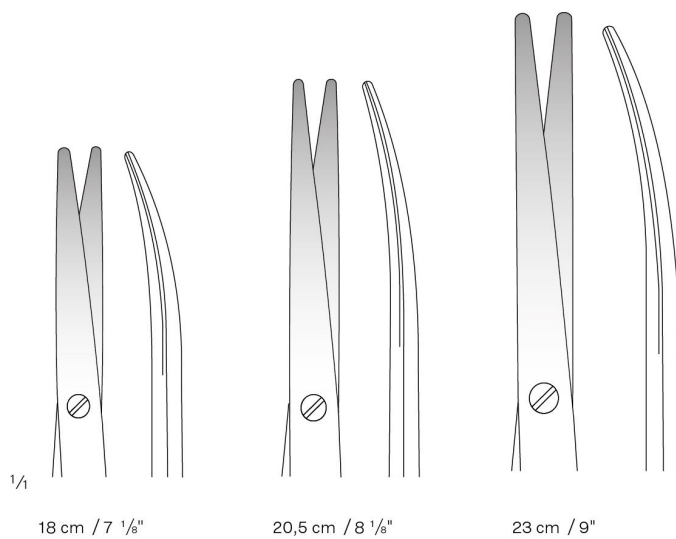

**Delicate Dissecting Scissors**

Feine Präparierscheren  
Tijeras finas de disección  
Ciseaux fins à dissection  
Forbici fini per dissezione



**FinoLine**



Metzenbaum Fino	Standard	TC Gold
18 cm / 7 1/8"	V02-238-18	V02-239-18
20,5 cm / 8 1/8"	V02-238-20	V02-239-20
23 cm / 9"	V02-238-23	V02-239-23

schlankes Modell, S-Form  
slender pattern, S-shaped  
modelo delgado, forma S  
modèle gracile, courbé en S  
modello delicato, curvo in forma S

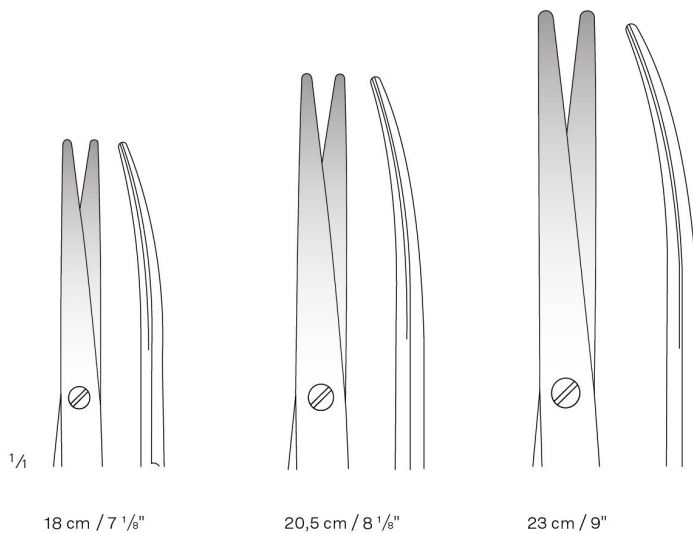

**FinoLine**

Forbici per dissezione, Forbici per chirurgia



**Salyer**

**V02-240-12**  
**V02-240-18**

feines Modell, eine Schneide mit Messerschliff  
 delicate pattern, one cutting edge with knife cut  
 modelo delicado, una hoja con afilado de cuchillo  
 modèle fin, une lame avec taille de couteau  
 modello fino, una lama con affilatura di coltello  
 für Lippen-, Kiefer-, Gaumenspalte  
 for Cleft Palate  
 para fisura paladar  
 pour fente du palais  
 per cheilo-labbro-palato schisi

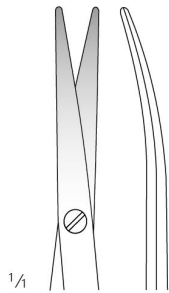

**V02-240-12**  
 12,5 cm / 4 7/8"

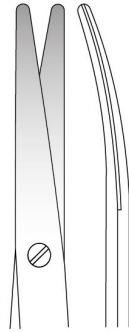

**V02-240-18**  
 18 cm / 7 1/8"



**Sanvenero**

**V02-241-14**  
**V02-242-14**

14 cm / 5 1/2"



**V02-241-14**

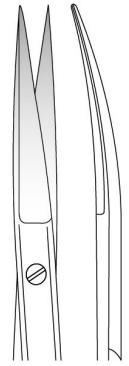

**V02-242-14**



**V02-243-11**  
**V02-244-11**

11 cm / 4 3/8"

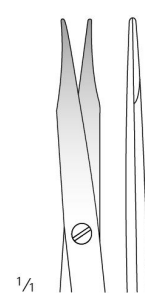

**V02-243-11**

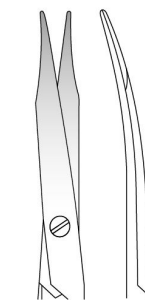

**V02-244-11**

## Operating Scissors

Chirurgische Scheren  
 Tijeras quirúrgicas  
 Ciseaux chirurgicaux  
 Forbici per chirurgia

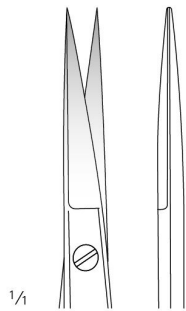



## Operating Scissors

Chirurgische Scheren  
Tijeras quirúrgicas  
Ciseaux chirurgicaux  
Forbici per chirurgia



Joseph	Standard	TC Gold	Super Cut
14,5 cm / 5 7/8"	V 02-248-14	V02-249-14	V02-250-14

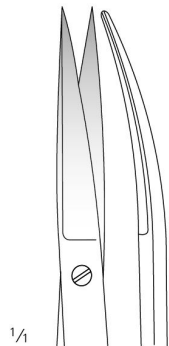

**Face-lift Scissors, Dissecting Scissors**

Face-lift-Scheren, Präparierscheren

Tijeras para Face-lift, Tijeras de disección

Ciseaux pour Face-lift, Ciseaux à dissection

Forbici per Face-lift, Forbici per dissezione

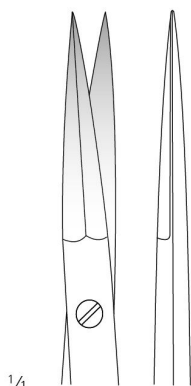

V02-251-14

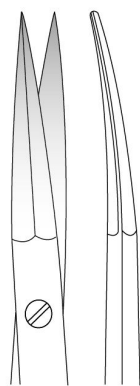

V02-252-14

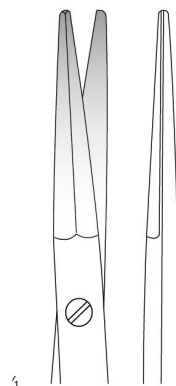

V02-253-14



V02-254-14

**Peck-Joseph**

V02-251-14

V02-252-14

14,5 cm / 5<sup>9</sup>/<sub>16</sub>"

**Peck-Joseph**

V02-253-14

V02-254-14

14,5 cm / 5<sup>9</sup>/<sub>16</sub>"

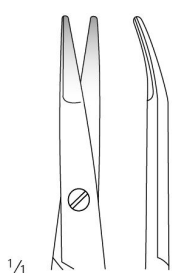

**Shea Vein Graft**

V02-255-12

12 cm / 4<sup>9</sup>/<sub>16</sub>"

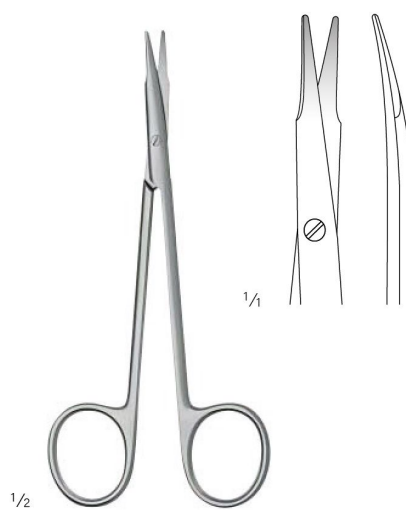

V02-256-13

13 cm / 5<sup>1</sup>/<sub>8</sub>"

Dissektions- u. Zahnfleischschere

Dissecting Scissors

Tijera de disección

Ciseaux à dissection

Forbici per dissezione



### Face-lift Scissors, Dissecting Scissors

Face-lift-Scheren, Präparierscheren

Tijeras para Face-lift, Tijeras de disección

Ciseaux pour Face-lift, Ciseaux à dissection

Forbici per Face-lift, Forbici per dissezione



Kilner	Standard	Super Cut
12 cm / 4 5/8"	V02-257-12	V02-258-12
15 cm / 5 7/8"	V02-257-15	V02-258-15

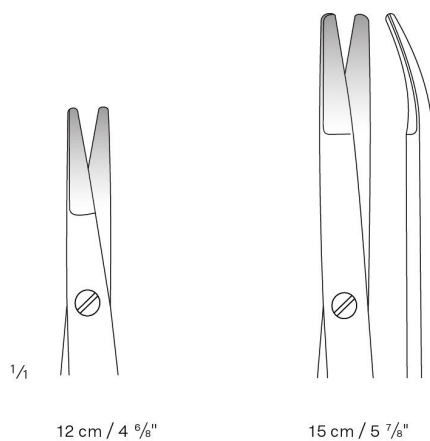

**Dissecting Scissors, Vascular Scissors**  
 Präparierscheren, Gefäßscheren  
 Tijeras de disección, Tijeras vasculares  
 Ciseaux à dissection, Ciseaux vasculaires  
 Forbici per dissezione, Forbici vascolari

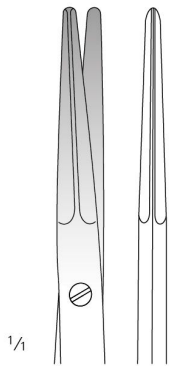

**V02-259-14**



**V02-260-14**



**Reynolds**  
**V02-261-14**  
 15,5 cm / 6 1/8"

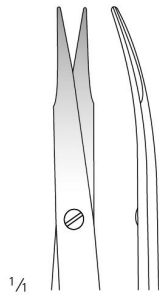

**Jameson**  
**V02-262-15**  
 15,5 cm / 6 1/8"



**Jameson**  
**V02-263-15**  
 15,5 cm / 6 1/8"  
 eine Schneide gezahnt  
 one toothed cutting edge  
 una hoja dentada  
 une lame dentelée  
 una lama dentata



**Dissecting Scissors, Vascular Scissors**  
 Präparierscheren, Gefäßscheren  
 Tijeras de disección, Tijeras vasculares  
 Ciseaux à dissection, Ciseaux vasculaires  
 Forbici per dissezione, Forbici vascolari



Reynolds	Standard	Super Cut
15,5 cm / 6 1/8"	V02-264-15	V02-265-15
18 cm / 7 1/8"	V02-264-18	V02-265-18



**Short Micro Scissors**  
 Kurze Mikroscheren  
 Micro-Tijeras, corto  
 Micro-Ciseaux, court  
 Micro-Forbici, corto



1/2  
**V02-266-12**  
 to  
**V02-270-12**  
 12 cm / 4 9/16"

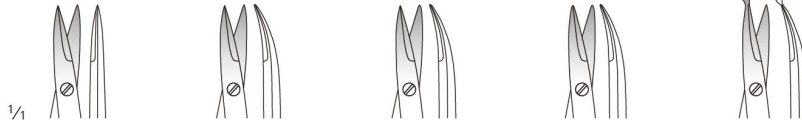

	●	A	A		D	
		spitz/spitz sharp/sharp agudo/agudo pointu/pointu appuntato/appuntato	spitz/spitz sharp/sharp agudo/agudo pointu/pointu appuntato/appuntato	spitz/stumpf sharp/blunt agudo/romo pointu/mousse appuntato/smusso	stumpf/stumpf blunt/blunt romo/romo mousse/mousse smusso/smusso	mit Knopf with button con botón avec bouton con bottone
	U	7 mm	7 mm	7 mm	7 mm	7 mm
	St	<b>V02-266-12</b>	<b>V02-267-12</b>	<b>V02-268-12</b>	<b>V02-269-12</b>	<b>V02-270-12</b>



1/2  
**V02-271-12**  
 to  
**V02-275-12**  
 12 cm / 4 9/16"



	●	A	A		D	
		spitz/spitz sharp/sharp agudo/agudo pointu/pointu appuntato/appuntato	spitz/spitz sharp/sharp agudo/agudo pointu/pointu appuntato/appuntato	spitz/stumpf sharp/blunt agudo/romo pointu/mousse appuntato/smusso	stumpf/stumpf blunt/blunt romo/romo mousse/mousse smusso/smusso	mit Knopf with button con botón avec bouton con bottone
	U	7 mm	7 mm	7 mm	7 mm	7 mm
	St	<b>V02-271-12</b>	<b>V02-272-12</b>	<b>V02-273-12</b>	<b>V02-274-12</b>	<b>V02-275-12</b>

A = Adventitia  
 D = Präparation  
 A-SB = Adventitia, ein gezahntes Blatt  
 D-SB = Präparation, ein gezahntes Blatt

A = Adventitia  
 D = Dissection  
 A-SB = Adventitia, one serrated blade  
 D-SB = Dissection, one serrated blade

A = Adventicia  
 D = Disección  
 A-SB = Adventicia, una hoja dentada  
 D-SB = Disección, una hoja dentada

A = Advantice  
 D = Dissection  
 A-SB = Advantice, une lame dentelée  
 D-SB = Dissection, une lame dentelée

A = Avventizia  
 D = Dissezione  
 A-SB = Avventizia, una lama dentata  
 D-SB = Dissezione, una lama dentata



**Dissecting Scissors, Vascular Scissors**  
Präparierscheren, Gefäßscheren  
Tijeras de disección, Tijeras vasculares  
Ciseaux à dissection, Ciseaux vasculaires  
Forbici per dissezione, Forbici vascolari



1/2

**V 02-276-20**  
**V 02-277-20**  
20 cm / 7 7/8"

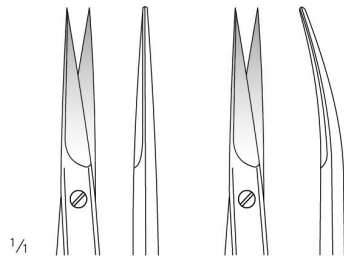

1/4

**V 02-276-20**

**V 02-277-20**



1/2

**Satinsky**  
**V 02-278-25**  
25,5 cm / 10"

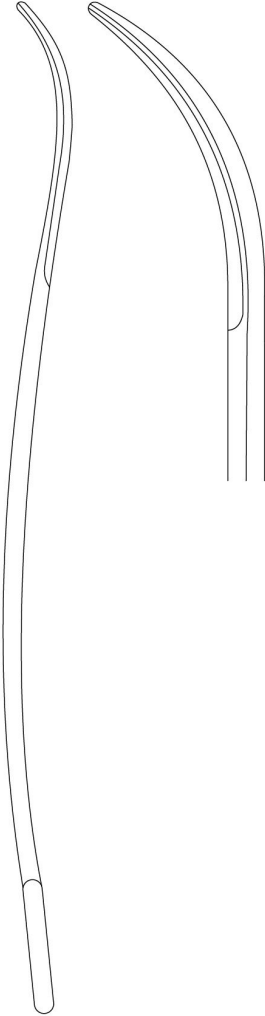

**Vascular Scissors, Coronary Scissors**  
 Gefäßscheren, Koronarscheren  
 Tijeras vasculares, Tijeras coronarias  
 Ciseaux vasculaires, Ciseaux coronaires  
 Forbici vascolari, Forbici per arteria coronaria

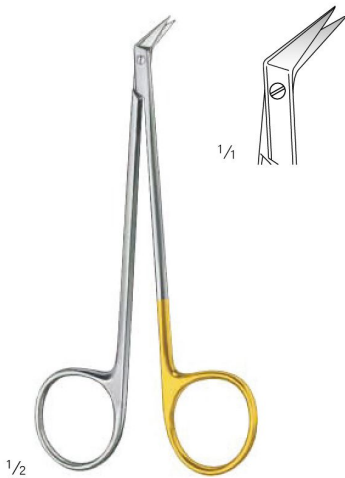

60°  
**Diethrich-Salyer**  
**V 02-279-12**

12 cm / 4 5/8"

ein Blatt mit Messerschliff  
 one cutting edge with knife cut  
 una hoja con afilado de cuchillo  
 une lame avec taille de couteau  
 una lama con affilatura di coltello

für Lippen-, Kiefer-, Gaumenspalte  
 for Cleft Palate  
 para fisura paladar  
 pour fente du palais  
 per cheilo-labbro-palato schisi



**Diethrich**  
**V 02-280-17**  
 17,5 cm / 6 7/8"

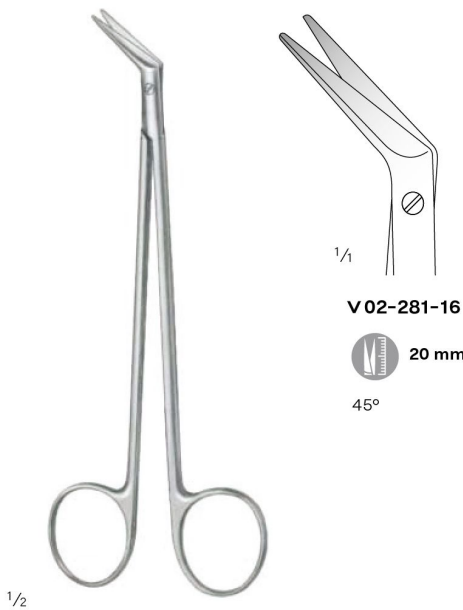

**De Bakey**  
**V 02-281-16**  
**V 02-282-16**  
 16 cm / 6 2/8"

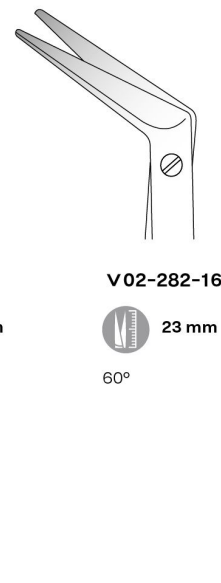

**V 02-282-16**  
 23 mm  
 60°

















1/2













18 cm / 7 1/8"		25°	45°	60°	90°	125°
	 10 mm St <b>V02-283-18</b>	 10 mm St <b>V02-284-18</b>	 10 mm St <b>V02-285-18</b>	 10 mm St <b>V02-286-18</b>	 10 mm St <b>V02-287-18</b>	
18 cm / 7 1/8"		25°	45°	60°	90°	125°
	 <b>Super Cut</b> 10 mm St <b>V02-288-18</b>	 10 mm St <b>V02-289-18</b>	 10 mm St <b>V02-290-18</b>	 10 mm St <b>V02-291-18</b>	 10 mm St <b>V02-292-18</b>	

**Dietrich-Potts**  
**V02-283-18**  
 to  
**V02-292-18**



1/2



18 cm / 7 1/8"		25°	45°	60°	90°	125°
	 7 mm St <b>V02-293-18</b>	 7 mm St <b>V02-294-18</b>	 7 mm St <b>V02-295-18</b>	 7 mm St <b>V02-296-18</b>	 7 mm St <b>V02-297-18</b>	
18 cm / 7 1/8"		25°	45°	60°	90°	125°
	 <b>Super Cut</b> 7 mm St <b>V02-298-18</b>	 7 mm St <b>V02-299-18</b>	 7 mm St <b>V02-300-18</b>	 7 mm St <b>V02-301-18</b>	 7 mm St <b>V02-302-18</b>	

**Dietrich-Potts**  
**V02-293-18**  
 to  
**V02-302-18**

**Vascular Scissors**  
 Gefäßscheren  
 Tijeras vasculares  
 Ciseaux vasculaires  
 Forbici vascolari



1/2

**Dietrich-Hegemann**  
**V02-303-18**  
 to  
**V02-312-14**

1/4

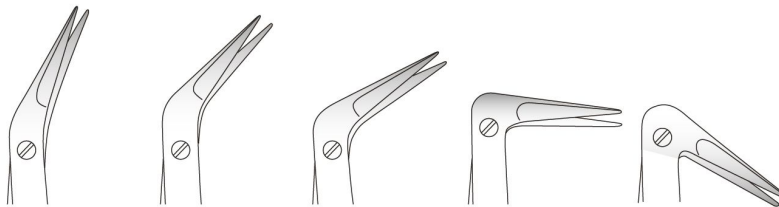

	25°	45°	60°	90°	125°
18 cm / 7 1/8"	15 mm	15 mm	15 mm	15 mm	15 mm
	<b>V02-303-18</b>	<b>V02-304-18</b>	<b>V02-305-18</b>	<b>V02-306-18</b>	<b>V02-307-18</b>
14 cm / 5 4/8"	15 mm	15 mm	15 mm	15 mm	15 mm
	<b>V02-308-14</b>	<b>V02-309-14</b>	<b>V02-310-14</b>	<b>V02-311-14</b>	<b>V02-312-14</b>



**Super Cut**

18 cm / 7 1/8"

14 cm / 5 4/8"





1/2

**Potts-Smith**  
**V02-313-18**  
 to  
**V02-317-19**

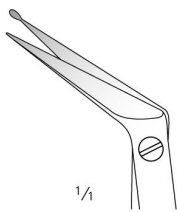

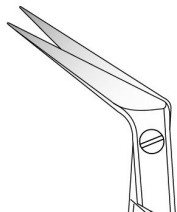

1/4

**V02-313-18**  
 18 cm / 7 1/8"  
 **20 mm**  
 60°

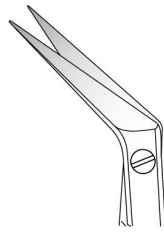

**V02-314-18**  
 18 cm / 7 1/8"  
 **20 mm**  
 60°



**V02-315-18**  
 18,5 cm / 7 2/8"  
 **20 mm**  
 40°



**V02-316-19**  
 19 cm / 7 4/8"  
 **20 mm**  
 25°

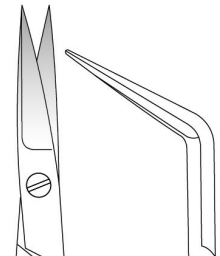

**V02-317-19**  
 19,5 cm / 7 5/8"  
 **20 mm**



**Vascular Scissors**  
 Gefäßscheren  
 Tijeras vasculares  
 Ciseaux vasculaires  
 Forbici vascolari



**Potts-Smith**  
**V02-318-18**  
 to  
**V02-320-19**

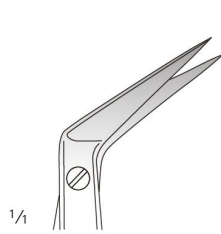

**V02-318-18**  
 18 cm / 7 1/8"  
 **20 mm**  
 60°

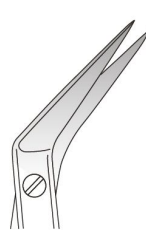

**V02-319-18**  
 18,5 cm / 7 2/8"  
 **20 mm**  
 40°

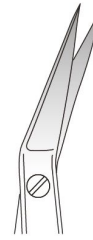

**V02-320-19**  
 19 cm / 7 4/8"  
 **20 mm**  
 25°



**Micro Scissors**  
 Mikroscheren  
 Micro-Tijeras  
 Micro-Ciseaux  
 Micro-Forbici



1/2

**V02-321-18**  
 to  
**V02-330-19**



	25°	45°	60°	90°	125°
18 cm / 7 1/8"	7 mm	7 mm	7 mm	7 mm	7 mm
	<b>V02-321-18</b>	<b>V02-322-18</b>	<b>V02-323-18</b>	<b>V02-324-18</b>	<b>V02-325-18</b>
	<b>V02-326-18</b>	<b>V02-327-18</b>	<b>V02-328-18</b>	<b>V02-329-18</b>	<b>V02-330-18</b>



1/2



	25°	45°	60°	90°	125°
18 cm / 7 1/8"	10 mm	10 mm	10 mm	10 mm	10 mm
	<b>V02-331-18</b>	<b>VC02-332-18</b>	<b>V02-333-18</b>	<b>V02-334-18</b>	<b>V02-335-18</b>
	<b>V02-336-18</b>	<b>VC02-337-18</b>	<b>V02-338-18</b>	<b>V02-339-18</b>	<b>V02-340-18</b>
21 cm / 8 2/8"					
	<b>V02-341-21</b>	<b>V02-342-21</b>	<b>V02-343-21</b>	<b>V02-344-21</b>	<b>V02-345-21</b>
23 cm / 9"					
	<b>V02-346-23</b>	<b>V02-347-23</b>	<b>V02-348-23</b>	<b>V02-349-23</b>	<b>V02-350-23</b>



**Micro Scissors**  
 Mikroscheren  
 Micro-Tijeras  
 Micro-Ciseaux  
 Micro-Forbici



1/2

**V 02-351-18**  
 to  
**V 02-355-18**



1/1



		25°	45°	60°	90°	125°
18 cm / 7 1/8"		7 mm	7 mm	7 mm	7 mm	7 mm
		<b>V 02-351-18</b>	<b>V 02-352-18</b>	<b>V 02-353-18</b>	<b>V 02-354-18</b>	<b>V 02-355-18</b>



1/2

**V 02-356-18**  
 to  
**V 02-370-23**



1/1



		25°	45°	60°	90°	125°
18 cm / 7 1/8"		10 mm	10 mm	10 mm	10 mm	10 mm
		<b>V 02-356-18</b>	<b>V 02-357-18</b>	<b>V 02-358-18</b>	<b>V 02-359-18</b>	<b>V 02-360-18</b>
21 cm / 8 2/8"		<b>V 02-361-21</b>	<b>V 02-362-21</b>	<b>V 02-363-21</b>	<b>V 02-364-21</b>	<b>V 02-365-21</b>
23 cm / 9"		<b>V 02-366-23</b>	<b>V 02-367-23</b>	<b>V 02-368-23</b>	<b>V 02-369-23</b>	<b>V 02-370-23</b>



**Micro Scissors**  
 Mikroscheren  
 Micro-Tijeras  
 Micro-Ciseaux  
 Micro-Forbici



**TC GOLD**

1/4



	25°	45°	60°	90°	125°
18 cm / 7 1/8"	10 mm	10 mm	10 mm	10 mm	10 mm
	<b>V02-371-18</b>	<b>V02-372-18</b>	<b>V02-373-18</b>	<b>V02-374-18</b>	<b>V02-375-18</b>

für feine verkalkte Gefäße  
 for delicate calcified vessels  
 para vasos finos calcificados  
 pour les vaisseaux calcifiés délicats  
 per vasi sottili calcificati

1/2

**V02-371-18**  
 to  
**V02-375-18**



**TC GOLD**

1/4



	25°	45°	60°	90°	125°
18 cm / 7 1/8"	10 mm	10 mm	10 mm	10 mm	10 mm
	<b>V02-376-18</b>	<b>V02-377-18</b>	<b>V02-378-18</b>	<b>V02-379-18</b>	<b>V02-380-18</b>

für feine verkalkte Gefäße  
 for delicate calcified vessels  
 para vasos finos calcificados  
 pour les vaisseaux calcifiés délicats  
 per vasi sottili calcificati

1/2

**V02-376-18**  
 to  
**V02-380-18**



**Vascular Scissors**  
 Gefäßscheren  
 Tijeras vasculares  
 Ciseaux vasculaires  
 Forbici vascolari



40°  
**Favaloro**  
**V02-381-14**  
 14,5 cm / 5 7/8"



**V02-382-12**  
 12 cm / 4 5/8"

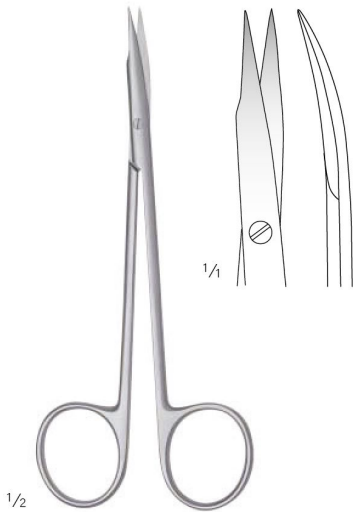

**V02-383-14**  
 14 cm / 5 4/8"



**V02-384-14**  
 14,5 cm / 5 7/8"







**Favaloro**  
**V02-385-18**  
 18 cm / 7 1/8"



**Favaloro**  
**V02-386-18**  
 18 cm / 7 1/8"



**Strully**  
**V02-387-22**  
**V02-388-22**  
 22 cm / 8 5/8"  
 Neurochirurgische Schere  
 Neurosurgical scissors  
 Tijeras para neurocirugia  
 Ciseaux pour neurochirurgie  
 Forbici per neurochirurgia

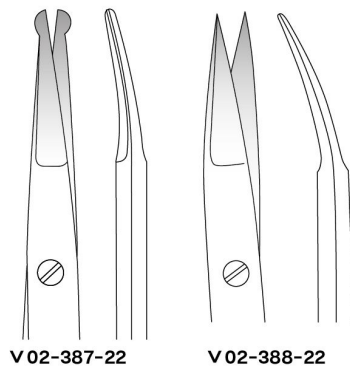

40°  
**Schmieden-Taylor**  
**V02-389-16**  
 16,5 cm / 6 5/8"  
 Duraschere  
 Dura scissors  
 Tijeras para duramadre  
 Ciseaux pour la dure-mère  
 Forbici per dura madre

**Dissecting Scissors**  
 Präparierscheren  
 Tijeras de disección  
 Ciseaux à dissection  
 Forbici per dissezione

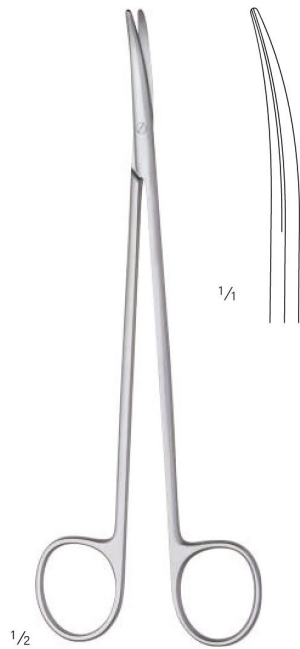

**Toennis-Adson**  
**V02-390-17**  
 17,5 cm / 6 <sup>7</sup>/<sub>8</sub>"



**V02-391-18**



**V02-392-18**



Arbeitslänge  
 working length  
 largo útil  
 longueur utile  
 lunghezza utile  
 120 mm

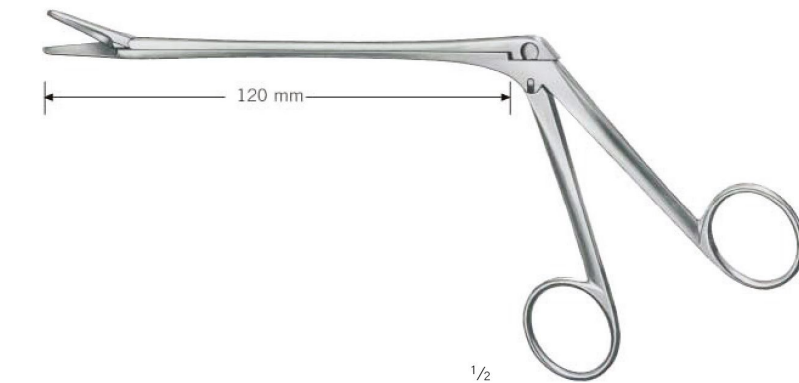
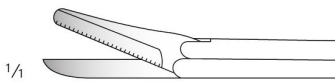

**Olivecrona**  
**V02-393-12**

Trigeminusschere  
 Trigeminal scissors  
 Tijeras para nervio trigémino  
 Ciseaux pour le nerf trigéminale  
 Forbici per il nervo trigemino  
 eine Schneide gezahnt  
 one toothed cutting edge  
 una hoja dentada  
 une lame dentelée  
 una lama dentata



**McIndoe**  
**V02-394-18**

18,5 cm / 7 2/8"  
 eine Schneide gezahnt  
 one toothed cutting edge  
 una hoja dentada  
 une lame dentelée  
 una lama dentata

**Tonsil Scissors**

Tonsillenscheren  
Tijeras para amígdalas  
Ciseaux pour les amygdales  
Forbici per tonsille

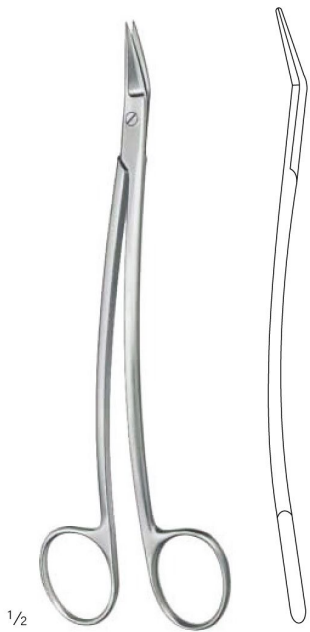

1/2

25°  
**Dean**  
**V 02-395-17**  
17,5 cm / 6 7/8"

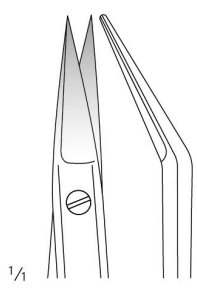

1/1

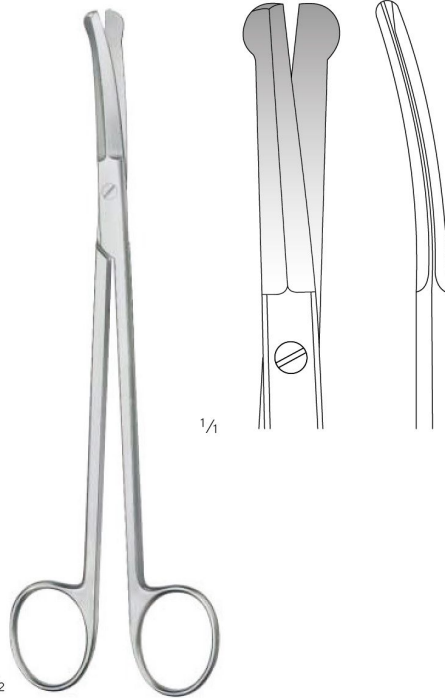

1/2

**Good**  
**V 02-396-19**  
19,5 cm / 7 5/8"

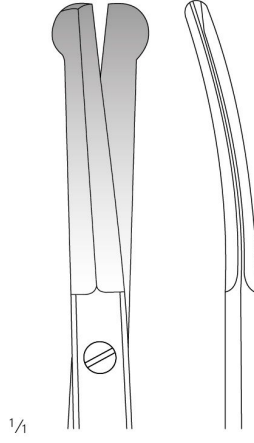

1/1



## Tonsil Scissors

Tonsillenscheren  
Tijeras para amígdalas  
Ciseaux pour les amygdales  
Forbici per tonsille



Dean	Standard	TC Gold
	25°	25°
17,5 cm / 6 $\frac{7}{8}$ "	V02-397-17	V02-398-17

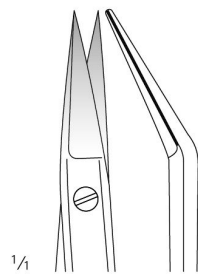

eine Schneide gezahnt  
one toothed cutting edge  
una hoja dentada  
une lame dentelée  
una lama dentata



**Nasal Scissors**  
 Nasenscheren  
 Tijeras nasales  
 Ciseaux nasaux  
 Forbici nasali



**TC GOLD**



1/2

40°  
**Fomon**  
**V02-399-14**  
 14,5 cm / 5 7/8"



**TC GOLD**



1/2

40°  
**Cottle**  
**V02-400-16**  
 16 cm / 6 2/8"

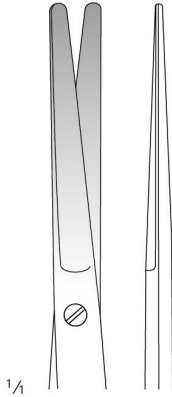

1/4



1/4

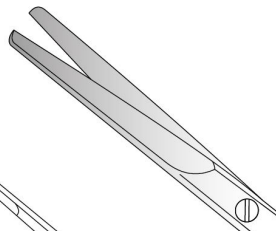

1/4



1/2

40°  
**Fomon**  
**V02-401-14**  
 14 cm / 5 4/8"



**Nasal Scissors**  
 Nasenscheren  
 Tijeras nasales  
 Ciseaux nasaux  
 Forbici nasali



40°  
**Cottle**  
**V02-402-15**  
 15,5 cm / 6 1/8"



40°  
**Heymann**  
**V02-403-18**  
 18 cm / 7 1/8"

Arbeitslänge  
 working length  
 largo útil  
 longueur utile  
 lunghezza utile  
 85 mm



40°  
**Heymann**  
**V02-404-18**  
 18 cm / 7 1/8"  
 eine Schneide gezahnt  
 one toothed cutting edge  
 una hoja dentada  
 une lame dentelée  
 una lama dentata

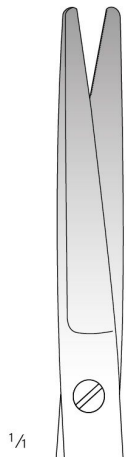

Arbeitslänge  
 working length  
 largo útil  
 longueur utile  
 lunghezza utile  
 85 mm



**Converse**  
**V02-405-10**  
**V02-406-10**  
 10,5 cm / 4 1/8"

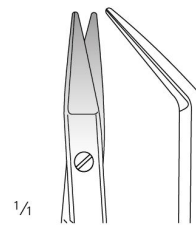

40°  
**V02-405-10**  
 stumpf  
 blunt  
 romo  
 mousse  
 smusso

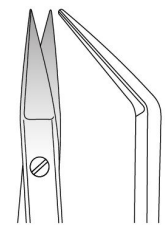

40°  
**V02-406-10**  
 spitz  
 sharp  
 agudo  
 pointu  
 appuntato

**Episiotomy Scissors**  
 Episiotomiescheren  
 Tijeras para episiotomía  
 Ciseaux à épisiotomie  
 Forbici per episiotomia



1/2

**Waldmann**  
**V02-407-18**

18 cm / 7 1/8"

eine Schneide gezahnt  
 one toothed cutting edge  
 una hoja dentada  
 une lame dentelée  
 una lama dentata

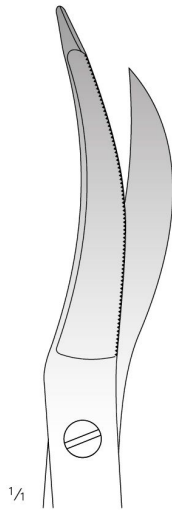

1/4



1/2

35°  
**Braun-Stadler**  
**V02-408-14**

14,5 cm / 5 5/8"

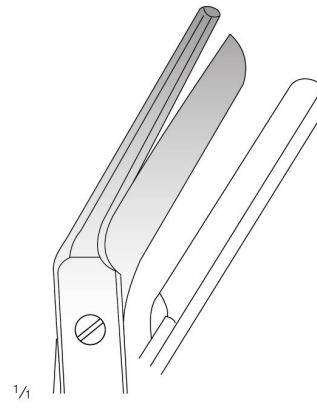

1/4



1/2

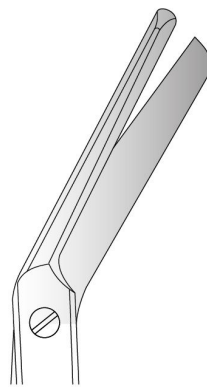

1/4

30°  
**Braun-Stadler**  
**V02-409-22**

22 cm / 8 5/8"





## Umbilical Scissors

Nabelschnurscheren

Tijeras umbilicales

Ciseaux pour le cordon ombilical

Forbici ombelicali



**Mod. USA**  
**V02-410-10**  
10,5 cm / 4 1/8"

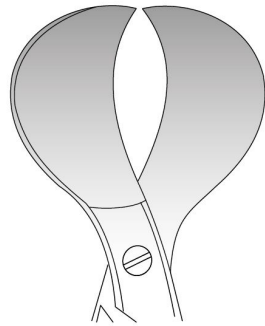

**Schuhmacher**  
**V02-411-15**  
15,5 cm / 6 1/8"

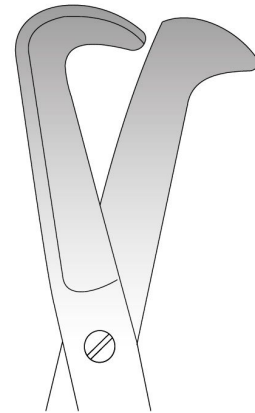

**Busch**  
**V02-412-16**  
16 cm / 6 2/8"

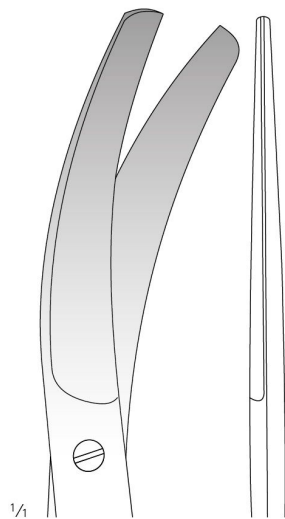

**Busch**  
**V02-413-16**  
16 cm / 6 2/8"  
eine Schneide gezahnt  
one toothed cutting edge  
una hoja dentada  
une lame dentelée  
una lama dentata

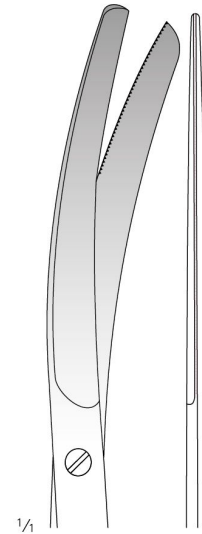

**Operating Scissors, Gum Scissors**

Chirurgische Scheren, Zahnfleischscheren  
 Tijeras quirúrgicas, Tijeras para encías  
 Ciseaux chirurgicaux, Ciseaux à gencives  
 Forbici per chirurgia, Forbici per gengiva



Goldman-Fox	Standard	TC Gold
13 cm / 5 1/8"	V02-414-13	V02-415-13

Standard	TC Gold
V02-416-13	V02-417-13

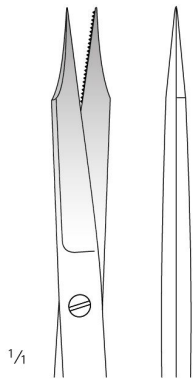

eine Schneide gezahnt  
 one toothed cutting edge  
 una hoja dentada  
 une lame dentelée  
 una lama dentata



eine Schneide gezahnt  
 one toothed cutting edge  
 una hoja dentada  
 une lame dentelée  
 una lama dentata



**Operating Scissors, Gum Scissors**

Chirurgische Scheren, Zahnfleischscheren  
Tijeras quirúrgicas, Tijeras para encías  
Ciseaux chirurgicaux, Ciseaux à gencives  
Forbici per chirurgia, Forbici per gengiva



1/2

**Wagner**

**V02-418-12**

**V02-419-12**

12 cm / 4 5/8"



1/4

**11-570-12-07**

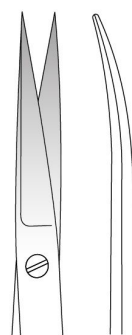

**11-571-12-07**

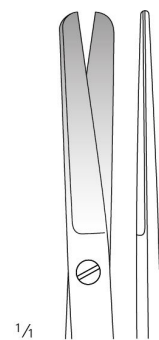

1/4

**V02-420-12**



**V02-421-12**



**V02-422-12**



1/2

**V02-420-12**

to

**V02-425-12**

12 cm / 4 5/8"

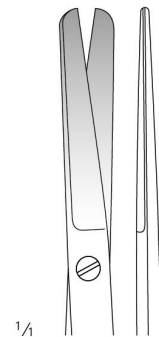

1/4

**V02-423-12**

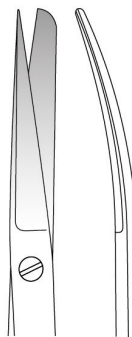

**V02-424-12**

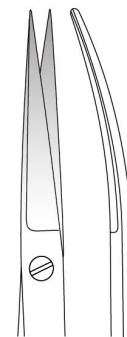

**V02-425-12**

**Operating Scissors, Gum Scissors**

Chirurgische Scheren, Zahnfleischscheren  
Tijeras quirúrgicas, Tijeras para encías  
Ciseaux chirurgicaux, Ciseaux à gencives  
Forbici per chirurgia, Forbici per gengiva



1/2

**La Grange**

**V02-426-11**

11,5 cm / 4 4/8"

S-Form, eine Schneide gezahnt  
S-shape, one toothed cutting edge  
forma S, una hoja dentada  
courbé en S, une lame dentelée  
curvo in forma S, una lama de

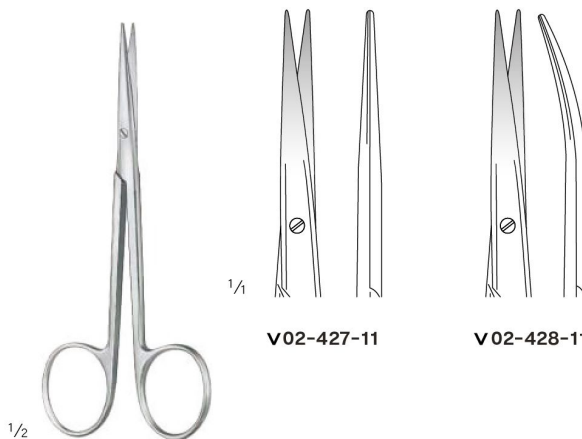

1/2

**V02-427-11**

**V02-428-11**

**V02-427-11**

**V02-428-11**

11,5 cm / 4 4/8"  
fein  
delicate  
fino  
fin  
fino



**Gum Scissors**

Zahnfleischscheren  
Tijeras para encías  
Ciseaux à gencives  
Forbici per gengiva



	Standard	TC Gold
	25°	25°
16 cm / 6 2/8"	<b>V02-429-16</b>	<b>V02-430-16</b>

	Standard	TC Gold
	25°	25°
	<b>V02-431-16</b>	<b>V02-432-16</b>

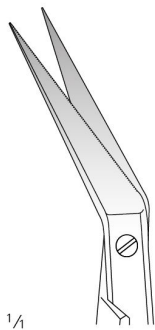

1/4

eine Schneide gezahnt  
one toothed cutting edge  
una hoja dentada  
une lame dentelée  
una lama dentata

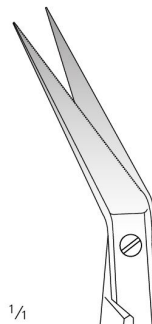

1/4

eine Schneide gezahnt  
one toothed cutting edge  
una hoja dentada  
une lame dentelée  
una lama dentata

**Iris Scissors**

Irisscheren  
Tijeras para iridectomía  
Ciseaux à iridectomie  
Forbici per iridectomia

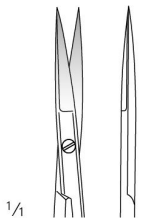

**V02-433-09**

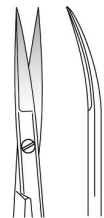

**V02-434-09**

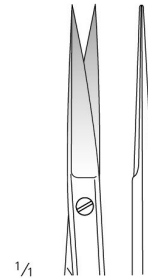

**V02-435-10**

10,5 cm / 4 1/8"  
extra flache Blätter  
extra flat blades  
hojas muy delgadas  
lames extrêmement plates  
con lame molto piate

**V02-433-09  
V02-434-09**

9 cm / 3 4/8"  
sehr fein  
very delicate  
muy fino  
très fin  
strafino



**V02-436-09**  
9 cm / 3 4/8"



**V02-437-10**  
10,5 cm / 4 1/8"



**V02-438-09**  
9 cm / 3 4/8"



**V02-439-10**  
10,5 cm / 4 1/8"

**V02-436-09  
to  
V02-439-10**



**Iris Scissors**

Irisscheren  
Tijeras para iridectomía  
Ciseaux à iridectomie  
Forbici per iridectomia



**Mod. Bonn**  
V02-440-09  
V02-441-09  
9 cm / 3 <sup>4</sup>/<sub>8</sub>"

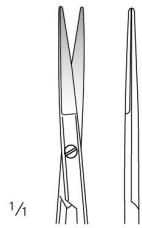

V02-440-09



V02-441-09



**V02-442-11**  
11,5 cm / 4 <sup>5</sup>/<sub>8</sub>"

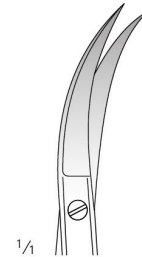

25°  
**Graefe**  
V02-443-10  
10 cm / 3 <sup>7</sup>/<sub>8</sub>"

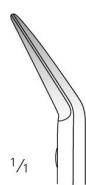

**V02-444-12**  
**V02-445-12**  
12,5 cm / 4 <sup>7</sup>/<sub>8</sub>"

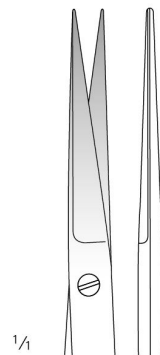

V02-444-12



V02-445-12

### Iris Scissors

Irisscheren  
Tijeras para iridectomía  
Ciseaux à iridectomie  
Forbici per iridectomia

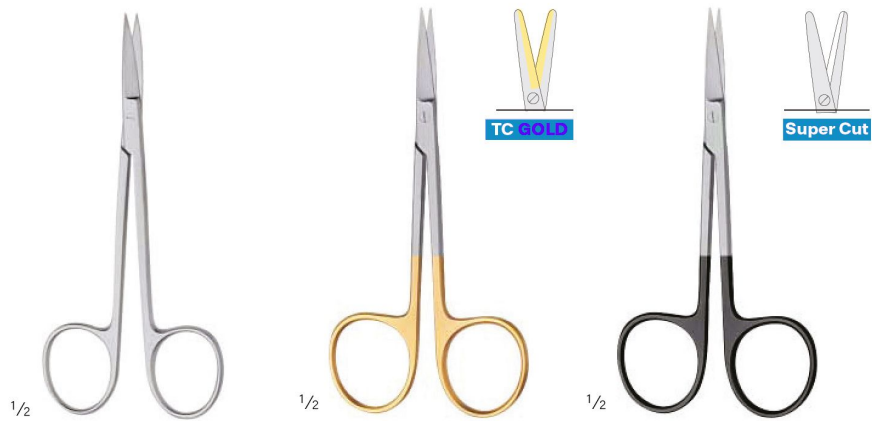

	Standard	TC Gold	Super Cut
11,5 cm / 4 5/8"	V02-446-11	V02-447-11	V02-448-11

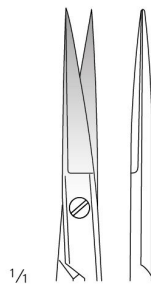



### Iris Scissors

Irisscheren  
Tijeras para iridectomía  
Ciseaux à iridectomie  
Forbici per iridectomia



	Standard	TC Gold	Super Cut
11,5 cm / 4 <sup>7</sup> / <sub>8</sub> "	V02-449-11	V02-450-11	V02-451-11

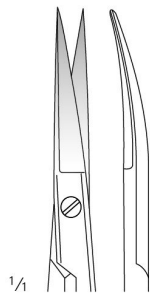

**Iris Scissors**

Irisscheren  
Tijeras para iridectomía  
Ciseaux à iridectomie  
Forbici per iridectomia

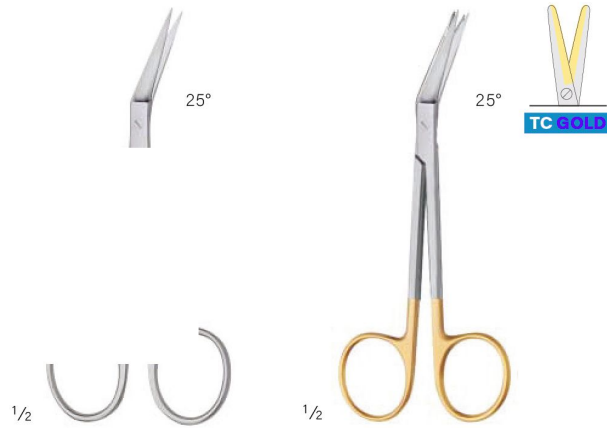

	Standard	TC Gold
11,5 cm / 4 1/8"	V02-452-11	V02-453-11

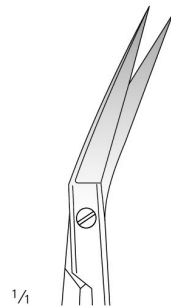

## Iris Scissors

Irisscheren  
Tijeras para iridectomía  
Ciseaux à iridectomie  
Forbici per iridectomia



Stevens	Standard	Super Cut
11 cm / 4 <sup>3</sup> / <sub>8</sub> "	V02-454-11	V02-455-11

Standard	Super Cut
V02-456-11	V02-457-11

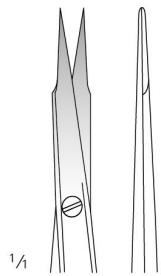

spitz/spitz  
sharp/sharp  
agudo/agudo  
pointu/pointu  
appuntato/appuntato

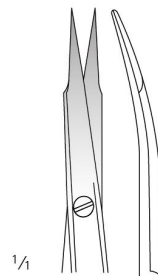

spitz/spitz  
sharp/sharp  
agudo/agudo  
pointu/pointu  
appuntato/appuntato

**Iris Scissors**

Irisscheren  
Tijeras para iridectomía  
Ciseaux à iridectomie  
Forbici per iridectomia



Stevens	Standard	Super Cut
11 cm / 4 3/8"	V02-458-11	V02-459-11

Standard	Super Cut
V02-460-11	V02-461-11

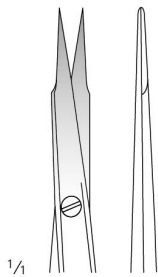

stumpf/stumpf  
blunt/blunt  
romo/romo  
mousse/mousse  
smusso/smusso

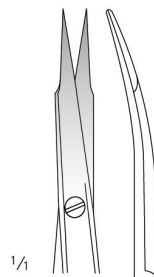

stumpf/stumpf  
blunt/blunt  
romo/romo  
mousse/mousse  
smusso/smusso



**Strabismus Scissors**  
 Strabismusscheren  
 Tijeras para estrabismo  
 Ciseaux à strabisme  
 Forbici per strabismo



**V02-462-11**  
**V02-463-11**  
 11,5 cm / 4 1/8"



**V02-464-11**  
 11,5 cm / 4 1/8"  
 Enukleationsschere  
 Enucleation Scissors  
 Tijera para enucleación  
 Ciseaux à énucléation  
 Forbici per enucleazione

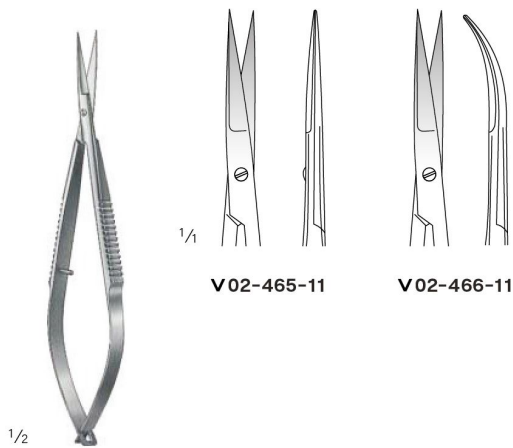

**Westcott**  
**V02-465-11**  
**V02-466-11**  
 11,5 cm / 4 1/8"

**Micro Scissors**  
 Mikroscheren  
 Micro-Tijeras  
 Micro-Ciseaux  
 Micro-Forbici



1/2

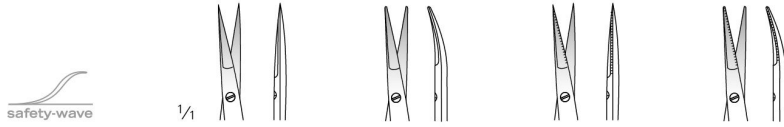

	A	D	A-SB	D-SB
	9 mm	9 mm	9 mm	9 mm
15 cm / 5 7/8"	<b>V02-467-15</b>	<b>V02-468-15</b>	<b>V02-469-15</b>	<b>V02-470-15</b>

**V02-467-15**  
 to  
**V02-474-15**

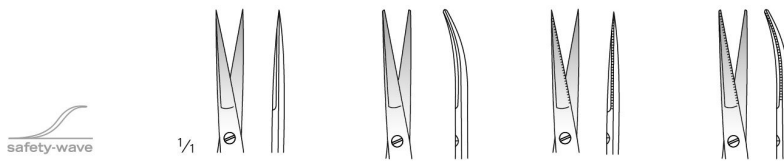

	A	D	A-SB	D-SB
	14 mm	14 mm	14 mm	14 mm
15 cm / 5 7/8"	<b>V02-471-15</b>	<b>V02-472-15</b>	<b>V02-473-15</b>	<b>V02-474-15</b>



1/2

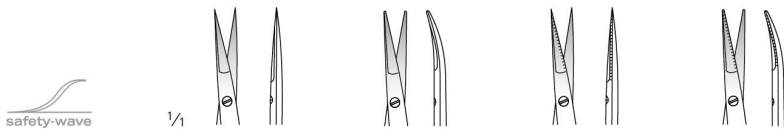

	A	D	A-SB	D-SB
	9 mm	9 mm	9 mm	9 mm
15 cm / 5 7/8"	<b>V02-475-15</b>	<b>V02-476-15</b>	<b>V02-477-15</b>	<b>V02-478-15</b>

**V02-475-15**  
 to  
**V02-482-15**

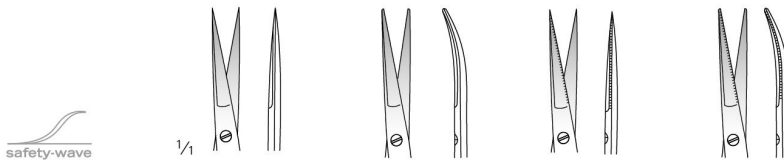

	A	D	A-SB	D-SB
	14 mm	14 mm	14 mm	14 mm
15 cm / 5 7/8"	<b>V02-479-15</b>	<b>V02-480-15</b>	<b>V02-481-15</b>	<b>V02-482-15</b>

A = Adventitia  
 D = Präparation  
 A-SB = Adventitia, ein gezahntes Blatt  
 D-SB = Präparation, ein gezahntes Blatt

A = Adventitia  
 D = Dissection  
 A-SB = Adventitia, one serrated blade  
 D-SB = Dissection, one serrated blade

A = Adventicia  
 D = Disección  
 A-SB = Adventicia, una hoja dentada  
 D-SB = Disección, una hoja dentada

A = Advantice  
 D = Dissection  
 A-SB = Advantice, une lame dentelée  
 D-SB = Dissection, une lame dentelée

A = Avventizia  
 D = Dissezione  
 A-SB = Avventizia, una lama dentata  
 D-SB = Dissezione, una lama dentata

**Micro Scissors**  
 Mikroscheren  
 Micro-Tijeras  
 Micro-Ciseaux  
 Micro-Forbici



1/2

**V02-483-15**  
 to  
**V02-499-23**



1/1

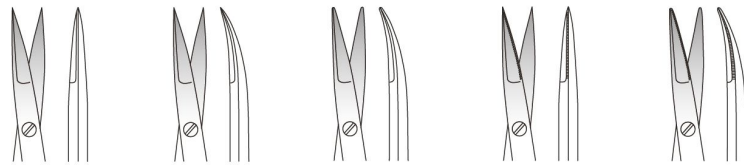

	A	A	D	A-SB	D-SB
	10 mm	10 mm	10 mm	10 mm	10 mm
15 cm / 5 7/8"	St <b>V02-483-15</b>	<b>V02-484-15</b>			
	Ti <b>V02-485-15</b>	<b>V02-486-15</b>			
18 cm / 7 1/8"	St <b>V02-487-18</b>	<b>V02-488-18</b>	<b>V02-489-18</b>	<b>V02-490-18</b>	<b>V02-491-18</b>
	Ti <b>V02-492-18</b>	<b>V02-493-18</b>			
21 cm / 8 2/8"	St <b>V02-494-21</b>	<b>V02-495-21</b>			
	Ti <b>V02-496-21</b>	<b>V02-497-21</b>			
23 cm / 9"	St <b>V02-498-23</b>	<b>V02-499-23</b>			

A = Adventitia  
 D = Präparation  
 A-SB = Adventitia, ein gezahntes Blatt  
 D-SB = Präparation, ein gezahntes Blatt

A = Adventitia  
 D = Dissection  
 A-SB = Adventitia, one serrated blade  
 D-SB = Dissection, one serrated blade

A = Adventicia  
 D = Disección  
 A-SB = Adventicia, una hoja dentada  
 D-SB = Disección, una hoja dentada

A = Advantice  
 D = Dissection  
 A-SB = Advantice, une lame dentelée  
 D-SB = Dissection, une lame dentelée

A = Avventizia  
 D = Dissezione  
 A-SB = Avventizia, una lama dentata  
 D-SB = Dissezione, una lama dentata



**Micro Scissors**  
 Mikroscheren  
 Micro-Tijeras  
 Micro-Ciseaux  
 Micro-Forbici



1/2

**V02-500-15**  
 to  
**V02-516-23**



1/1

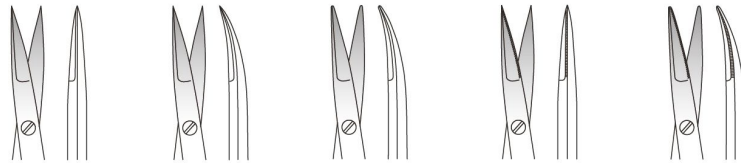

	A	A	D	A-SB	D-SB
	10 mm	10 mm	10 mm	10 mm	10 mm
15 cm / 5 7/8"	St <b>V02-500-15</b> Ti <b>V02-502-15</b>	<b>V02-501-15</b> <b>V02-503-15</b>			
18 cm / 7 1/8"	St <b>V02-504-18</b> Ti <b>V02-509-18</b>	<b>V02-505-18</b> <b>V02-510-18</b>	<b>V02-506-18</b>	<b>V02-507-18</b>	<b>V02-508-18</b>
21 cm / 8 2/8"	St <b>V02-511-21</b> Ti <b>V02-513-21</b>	<b>V02-512-21</b> <b>V02-514-21</b>			
23 cm / 9"	St <b>V02-515-23</b>	<b>V02-516-23</b>			



A = Adventitia      A = Adventitia      A = Adventicia      A = Advantice      A = Avventizia  
 D = Präparation      D = Dissection      D = Dissección      D = Dissection      D = Dissezione  
 A-SB = Adventitia, ein gezahntes Blatt      A-SB = Adventitia, one serrated blade      A-SB = Adventicia, una hoja dentada      A-SB = Advantice, une lame dentelée      A-SB = Avventizia, una lama dentata  
 D-SB = Präparation, ein gezahntes Blatt      D-SB = Dissection, one serrated blade      D-SB = Dissección, una hoja dentada      D-SB = Dissection, une lame dentelée      D-SB = Dissezione, una lama dentata



**Micro Scissors**  
 Mikroscheren  
 Micro-Tijeras  
 Micro-Ciseaux  
 Micro-Forbici



1/2

**Jacobson**  
**V02-517-20**  
 to  
**V02-520-23**

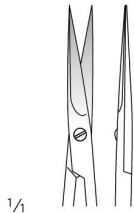

1/4

**V02-517-20**  
 20,5 cm / 8 1/8"

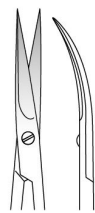

**V02-518-20**  
 20 cm / 7 7/8"



**V02-519-20**  
 20,5 cm / 8 1/8"

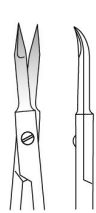

**V02-520-20**  
 20 cm / 7 7/8"

**Micro Scissors**  
 Mikroscheren  
 Micro-Tijeras  
 Micro-Ciseaux  
 Micro-Forbici



1/2

**V 02-521-20**  
**V 02-521-18**

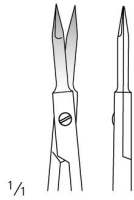

1/4

**V 02-521-20**  
 20 cm / 7 7/8"

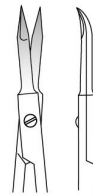

**V 02-521-18**  
 18 cm / 7 1/8"



1/2

**V 02-522-19**  
 to  
**V 02-524-18**

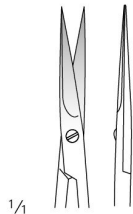

1/4

**V 02-522-19**  
 19 cm / 7 4/8"



**V 02-523-18**  
 18,5 cm / 7 2/8"  
 aufwärts gebogen  
 bent upwards  
 angulado hacia arriba  
 courbée en haut  
 angolato in alto

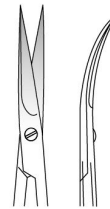

**V 02-524-18**  
 18,5 cm / 7 2/8"  
 abwärts gebogen  
 bent downwards  
 angulado hacia abajo  
 coudé en bas  
 angolato in basso



**Micro Scissors, Micro Dissecting Scissors**  
 Mikroscheren, Mikro-Präparierscheren  
 Micro-Tijeras, Micro-Tijeras de disección  
 Micro-Ciseaux, Micro-Ciseaux à dissection  
 Micro-Forbici, Micro-Forbici per dissezione

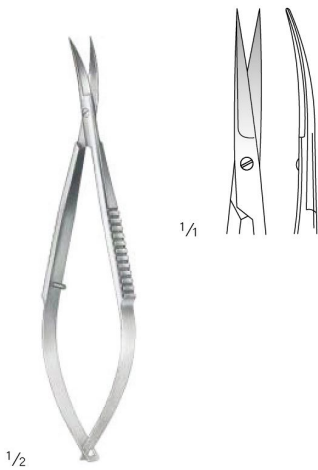

**V 02-525-12**  
 12 cm / 4 5/8"

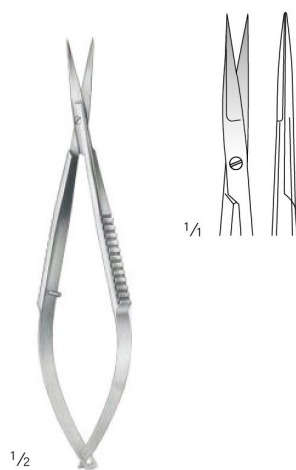

**V 02-526-12**  
 12 cm / 4 5/8"



**Biemer**  
**V 02-527-12**  
 12 cm / 4 5/8"

Mikro-Venenscherer  
 Micro scissors for veins  
 Tijeras de micro para venas  
 Micro-ciseaux pour les veines  
 Forbici micro per vene

Zum Auffrischen von Gefäßstümpfen. Kein Abgleiten des Gefäßes und glatte, saubere Durchtrennung

For roughening vessel ends, vessel cannot slip off, clean, smooth cut

Renovación de extremos vasculares. Ningún resbalamiento del vaso, cortes limpios y lisos

Pour rafraîchir des moignons vasculaires. Les vaisseau ne peut pas glisser, coupe lisse et propre

Per cruentare le estremità vasili. Senza scivolamento del vaso, con distacco preciso



**V 02-528-10**  
 10 cm / 3 7/8"

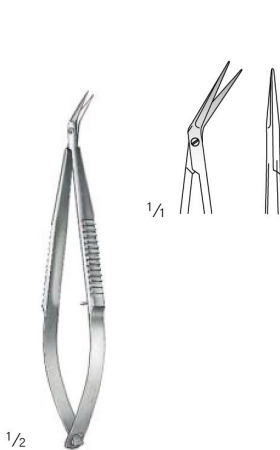

**V 02-529-09**  
 9,5 cm / 3 5/8"

**Micro Scissors**  
 Mikroscheren  
 Micro-Tijeras  
 Micro-Ciseaux  
 Micro-Forbici



**Jaboma**  
**V02-530-18**  
 18 cm / 7 1/8"

für Lippen-, Kiefer-, Gaumenspalte  
 for Cleft Palate  
 para fisura paladar  
 pour fente du palais  
 per cheilo-labbro-palato schisi



**Jaboma**  
**V02-531-18**  
 18 cm / 7 1/8"

für Lippen-, Kiefer-, Gaumenspalte  
 for Cleft Palate  
 para fisura paladar  
 pour fente du palais  
 per cheilo-labbro-palato schisi



**Jaboma**  
**V02-532-18**  
 18 cm / 7 1/8"

für Lippen-, Kiefer-, Gaumenspalte  
 for Cleft Palate  
 para fisura paladar  
 pour fente du palais  
 per cheilo-labbro-palato schisi

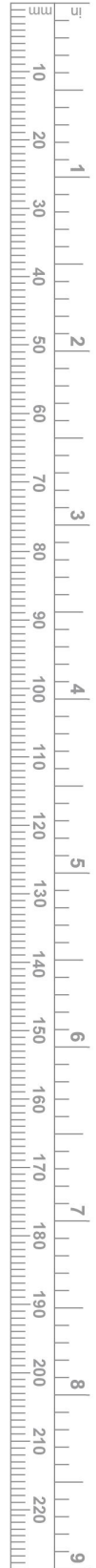

**V02-533-19**  
 19 cm / 7 4/8"

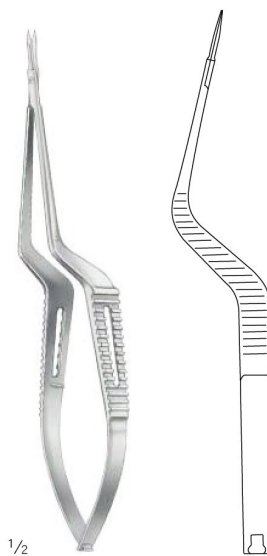

**V02-534-15**  
**V02-535-15**  
 15,5 cm / 6 1/8"

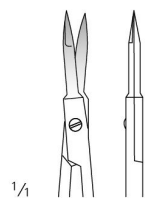

**V02-534-15**

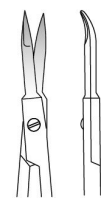

**V02-535-15**

**Enterotomy Scissors**  
 Darmscheren  
 Tijeras para intestino  
 Ciseaux-entérotomes  
 Forbici per enterotomia

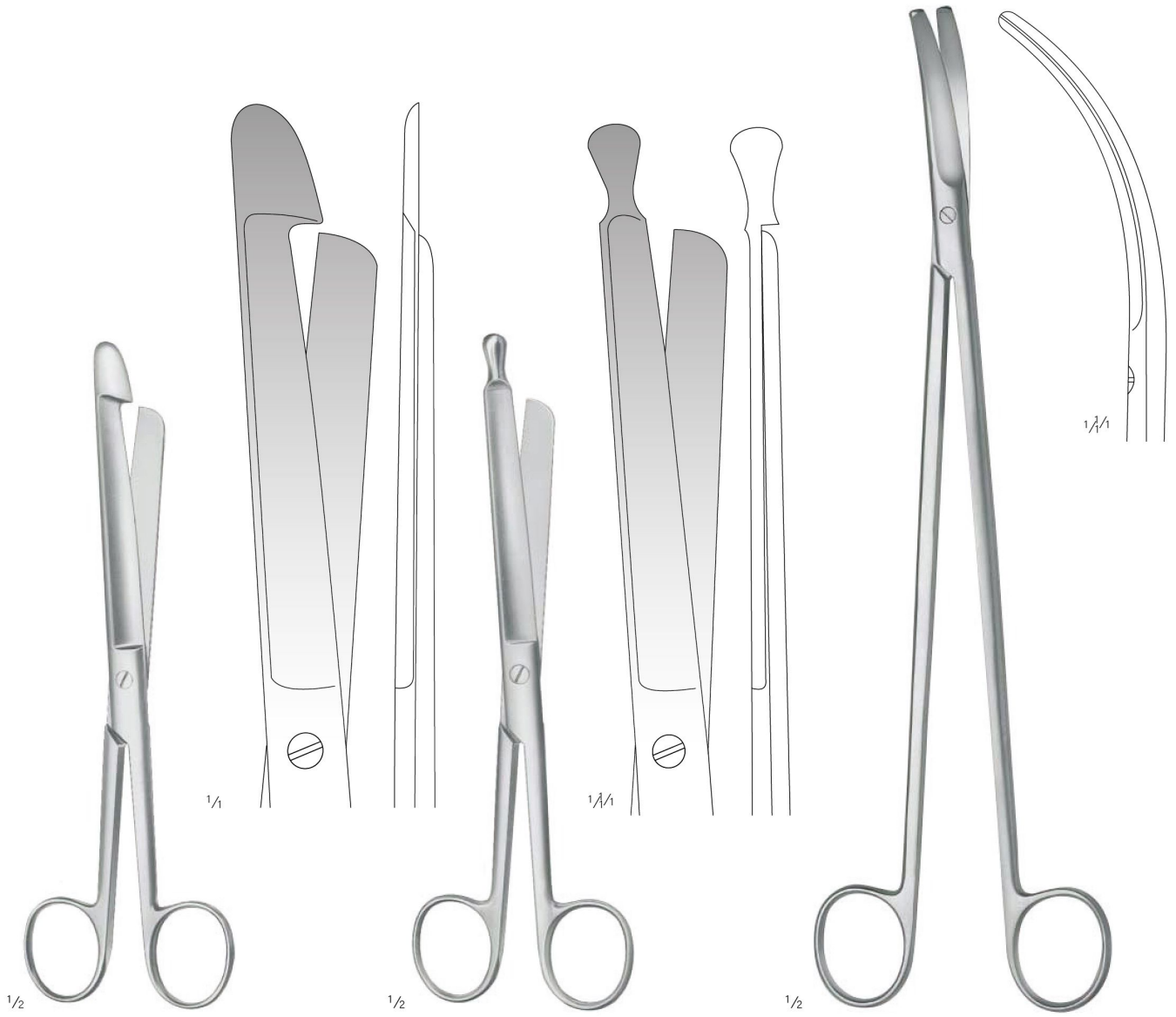

**V02-536-21**  
 21,5 cm / 8 4/8"

**V02-537-21**  
 21,5 cm / 8 4/8"

**V02-538-32**  
 32,5 cm / 12 5/8"  
 Rektumschere  
 Rectal Scissors  
 Tijera para recto  
 Ciseaux pour rectum  
 Forbici per il retto

**Dissecting Scissors, Face-lift Scissors, Stitch Scisso**

Präparierscheren, Face-lift-Scheren, Fadenscheren  
Tijeras de disección, Tijeras para Face-Lift, Tijeras para  
Ciseaux à dissection, Ciseaux pour Face-lift, Ciseaux à  
Forbici per dissezione, Forbici per Face-lift, Forbici per leg



**Salyer**

**V02-539-09**

9,5 cm / 3 9/16"

für Lippen-, Kiefer-, Gaumenspalte  
for Cleft Palate  
para fisura paladar  
pour fente du palais  
per cheilo-labbro-palato schisi

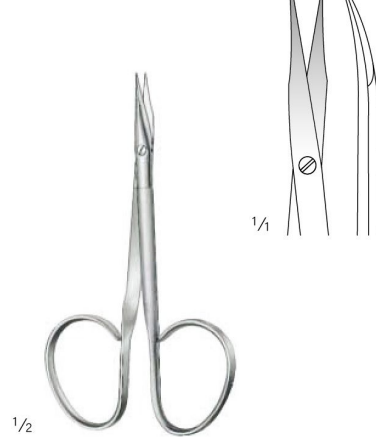

**Salyer**

**V02-540-10**

10 cm / 3 7/8"

für Lippen-, Kiefer-, Gaumenspalte  
for Cleft Palate  
para fisura paladar  
pour fente du palais  
per cheilo-labbro-palato schisi

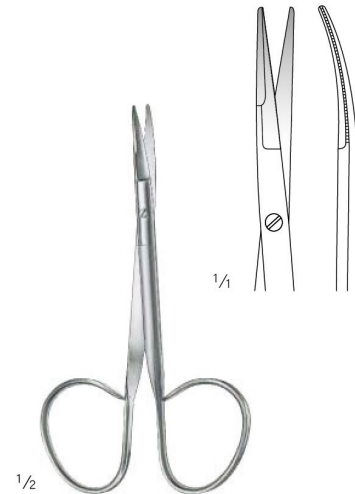

**Kaye**

**V02-541-11**

11 cm / 4 3/8"

beide Schneiden gezahnt  
both cutting edges serrated  
ambos filos dentados  
deux lames dentées  
entrambe le lame dentate



**Northbent**

**V02-542-13**

13 cm / 5 1/8"



**Spencer**

**V02-543-09**

9 cm / 3 4/8"



**Stitch Scissors**  
 Fadenscheren  
 Tijeras para hilos  
 Ciseaux à ligatures  
 Forbici per legature

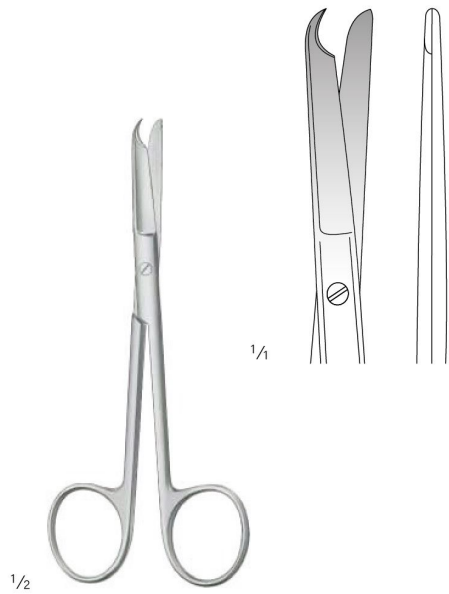

**Spencer**  
**V 02-544-13**  
 13 cm / 5 1/8"



**Buck**  
**V 02-545-14**  
**V 02-545-18**

**V 02-545-14**  
 14,5 cm / 5 9/16"

**V 02-545-18**  
 18 cm / 7 1/8"

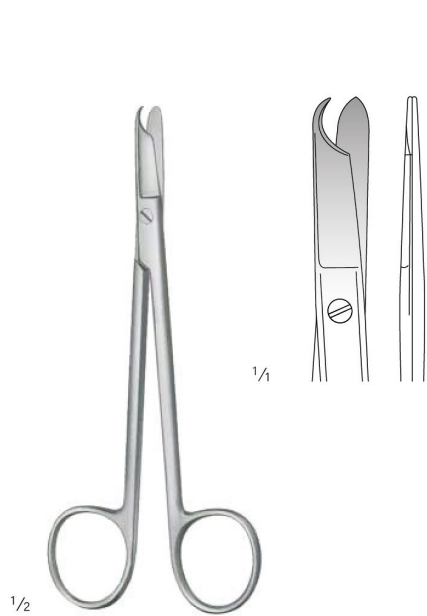

**Littauer**  
**V 02-546-14**  
 14 cm / 5 4/8"



**Eiselsberg**  
**V 02-547-12**  
 12 cm / 4 9/8"

## Wire Cutting Scissors

Drahtscheren  
Tijeras para cortar hilos de acero  
Ciseaux coupe-fil  
Forbici per tagliare fili metallici



1/2

**Universal**  
**V02-548-12**



1/2

**Universal**  
**V02-549-12**

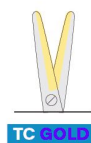

	Standard	TC Gold
12 cm / 4 6/8"	<b>V02-548-12</b>	<b>V02-549-12</b>
	max Ø = 0,4 mm weicher Draht soft wire alambre blando fil métallique souple filo morbido	max Ø = 1,0 mm      max Ø = 0,5 mm weicher Draht      harter Draht soft wire              hard wire alambre blando      alambre duro fil métallique souple      fil métallique raide filo morbido              filo rigido

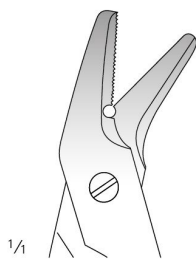

1/1

eine Schneide gezahnt  
one toothed cutting edge  
una hoja dentada  
une lame dentelée  
una lama dentata





**Wire Cutting Scissors**

Drahtscheren

Tijeras para cortar hilos de acero

Ciseaux coupe-fil

Forbici per tagliare fili metallici



**Beebee**  
V 02-550-10  
to  
V 02-553-12

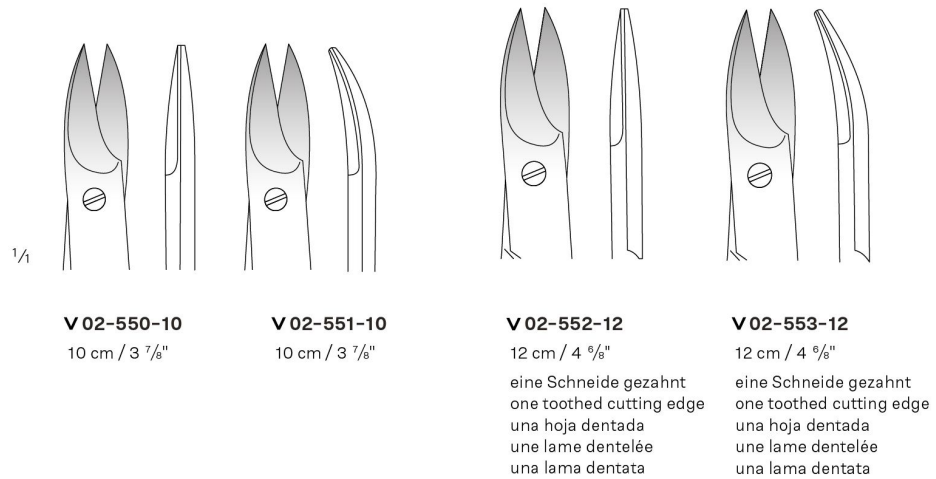

**Dissecting Scissors**  
 highMed-Präparierscheren  
 Tijeras de disección  
 Ciseaux à dissection  
 Forbici per dissezione



**Lillehei-Potts**  
**V 02-554-18**  
 18 cm / 7 1/8"

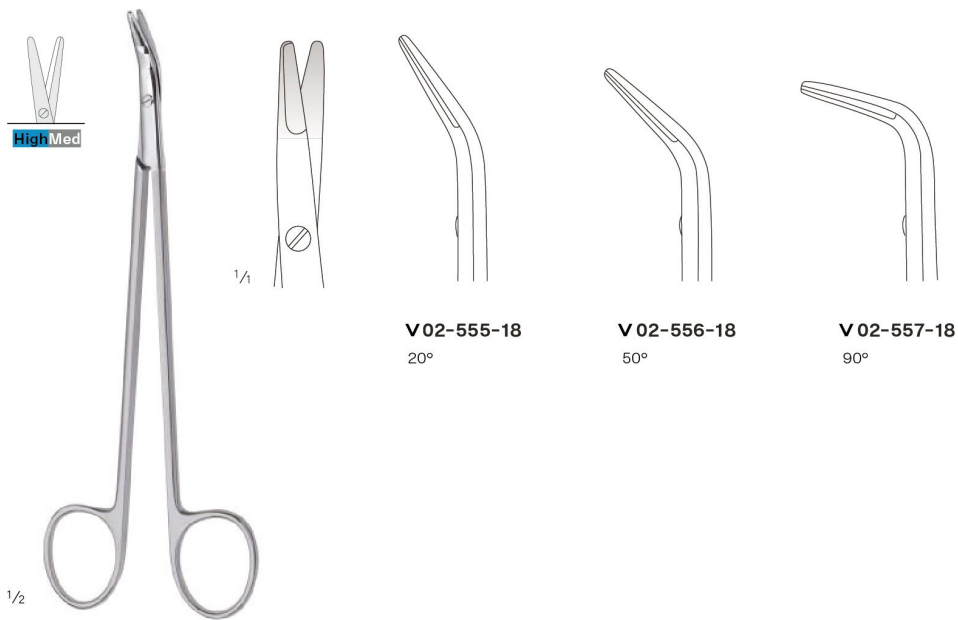

**Potts-De Martell**  
**V 02-555-18**  
 to  
**V 02-557-18**  
 18 cm / 7 1/8"



**Ligature Scissors**  
 Ligaturscheren  
 Tijeras para ligaduras  
 Ciseaux pour ligatures  
 Forbici per legature

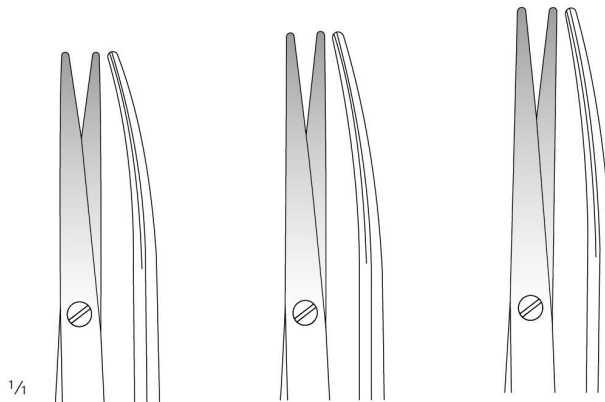
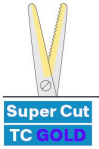

**V02-558-11**  
 11,5 cm / 4 5/8"

**V02-558-14**  
 14,5 cm / 5 3/4"

**V02-558-18**  
 18 cm / 7"

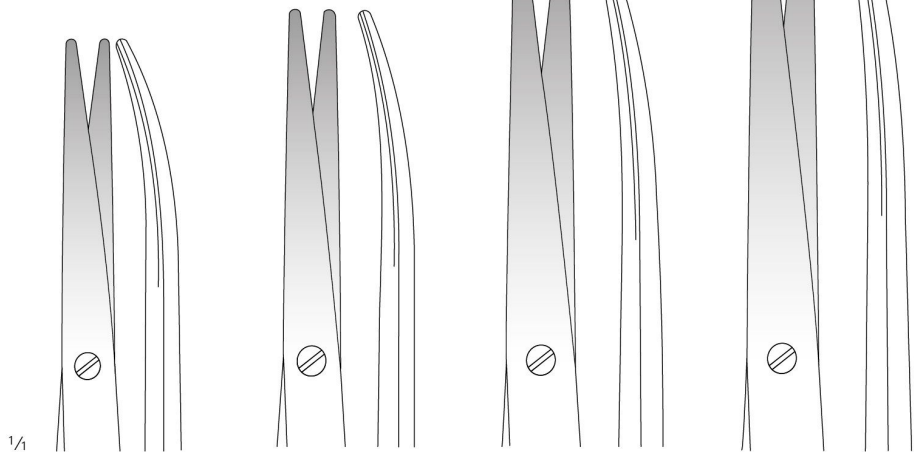

**V02-558-20**  
 20,5 cm / 8"

**V02-558-23**  
 23 cm / 9"

**V02-558-25**  
 25 cm / 9 3/4"

**V02-558-30**  
 30 cm / 11 5/8"

**V02-558-11**  
 to  
**V02-558-30**

für Synthetik-Nahtmaterial,  
 eine Schneide gezahnt

for synthetic suture material,  
 one toothed cutting edge

para hilos de sutura sintéticos,  
 una hoja dentada

pour matériel de suture synthétique,  
 une lame dentelée

per materiale di sutura sintetico,  
 una lama dentata



## Ligature Scissors

Ligaturscheren  
Tijeras para ligaduras  
Ciseaux pour ligatures  
Forbici per legature



02



1/2

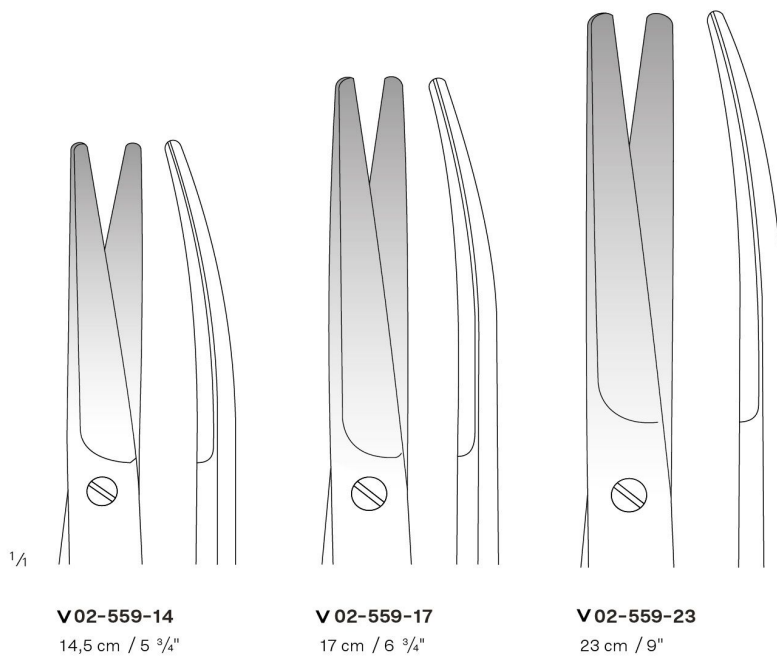

**V02-559-14**  
14,5 cm / 5 3/4"

**V02-559-17**  
17 cm / 6 3/4"

**V02-559-23**  
23 cm / 9"

**V02-559-14**  
to  
**V02-559-23**

für Synthetik-Nahtmaterial,  
eine Schneide gezahnt

for synthetic suture material,  
one toothed cutting edge

para hilos de sutura sintéticos,  
una hoja dentada

pour matériel de suture synthétique,  
une lame dentelée

per materiale di sutura sintetico,  
una lama dentata



106



## TCC-BlackLine Scissors

TCC-BlackLine-Scheren  
Tijeras TCC-BlackLine  
Ciseaux TCC-BlackLine  
Forbici TCC-BlackLine



TCC BLACKLINE

FinoLine TC GOLD



**V 02-560-14**  
14,5 cm / 5 5/8"

**V 02-560-18**  
18 cm / 7 1/8"

### Tönnis-Adson TCC-BlackLine

**V 02-560-14**

**V 02-560-18**

sehr fein  
very delicate  
muy fino  
très fin  
strafino

Keramik-Beschichtung,  
eine Schneide gezahnt

Coated with ceramics,  
one toothed cutting edge

Cubierto con material de cerámicas,  
una hoja dentada

Recouvert avec matériau de la  
céramique, une lame dentelée

Ricoprito con materiale di ceramica,  
una lama dentata



**Dissecting Scissors, Operating Scissors**  
 Präparierscheren, Chirurgische Scheren  
 Tijeras de disección, Tijeras quirúrgicas  
 Ciseaux à dissection, Ciseaux chirurgicaux  
 Forbici per dissezione, Forbici per chirurgia



1/2

**Metzenbaum-Thorek**

**V 02-561-20**  
to  
**V 02-561-28**

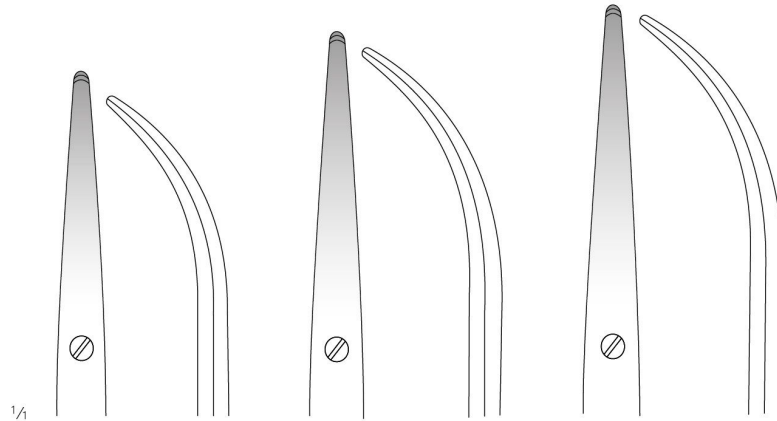

1/4

**V 02-561-20**  
20 cm / 7 7/8"

**V 02-561-23**  
23 cm / 9"

**V 02-561-28**  
28 cm / 11"



1/2

**Lexer**

**V 02-562-21**  
**V 02-563-21**  
21 cm / 8 2/8"

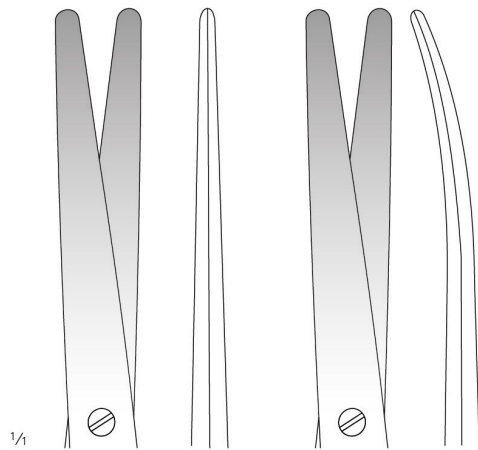

1/4

**V 02-562-21**

**V 02-563-21**



1/2

**Mayo-Lexer**

**V 02-564-16**  
16 cm / 6 2/8"

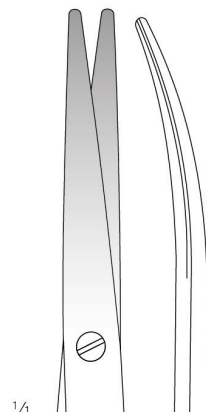

1/4



**Delicate Dissecting Scissors**

Feine Präparierscheren  
Tijeras finas de disección  
Ciseaux fins à dissection  
Forbici fini per dissezione



**FinoLine**



1/2

**Metzenbaum-Fino**  
V 02-565-26  
V 02-565-28

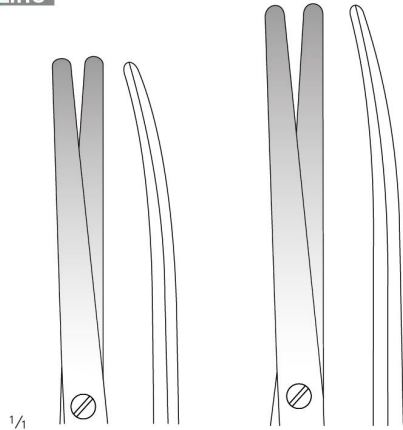

1/4

**V 02-565-26**  
26 cm / 10 2/8"

**V 02-565-28**  
28,5 cm / 11 2/8"



1/2

**Metzenbaum-Fino**  
V 02-566-18  
to  
V 02-566-23

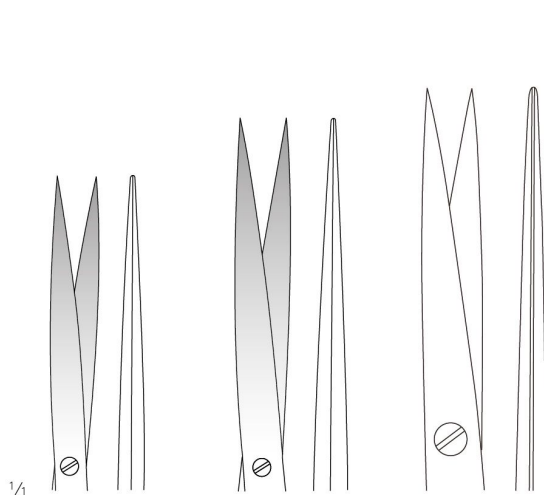

1/4

**V 02-566-18**  
18 cm / 7 1/8"

**V 02-566-20**  
20 cm / 7 7/8"

**V 02-566-23**  
23 cm / 9"

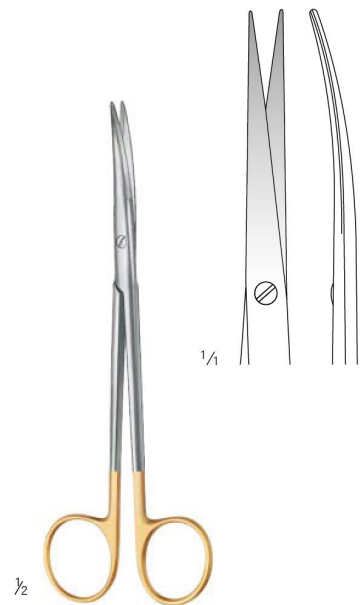

1/2

**Metzenbaum-Lahey**  
V 02-567-14  
14,5 cm / 5 6/8"  
schlankes Modell  
slender pattern  
modelo delgado  
modèle gracile  
modello delicato



**Delicate Dissecting Scissors**

Feine Präparierscheren  
 Tijeras finas de disección  
 Ciseaux fins à dissection  
 Forbici fini per dissezione

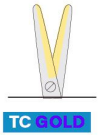

**FinoLine**



Toennis-Adson	TC Gold	Super Cut TC	TCC BlackLine
17,5 cm / 6 7/8"	V02-568-17	V02-569-17	V02-570-17





**Delicate Dissecting Scissors**

Feine Präparierscheren  
Tijeras finas de disección  
Ciseaux fins à dissection  
Forbici fini per dissezione



TC GOLD



**V02-571-20**  
20,5 cm / 8 1/8"

**V02-571-23**  
23 cm / 9"

**Metzenbaum-Fino**

**V02-571-20**  
**V02-571-23**

schlankes Modell  
slender pattern  
modelo delgado  
modèle gracile  
modello delicato



**Face-lift Scissors**  
 Face-lift-Scheren  
 Tijeras para Face-Lift  
 Ciseaux pour Face-lift  
 Forbici per Face-lift

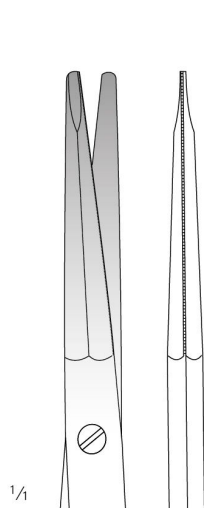
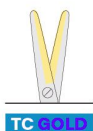

**V 02-572-20**  
 20 cm / 7 7/8"

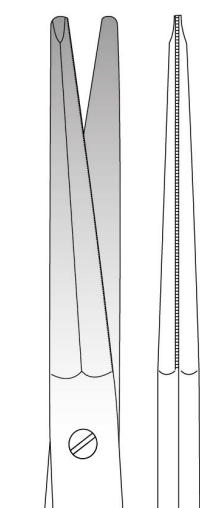

**V 02-572-23**  
 23 cm / 9"

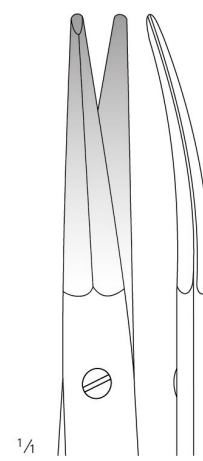
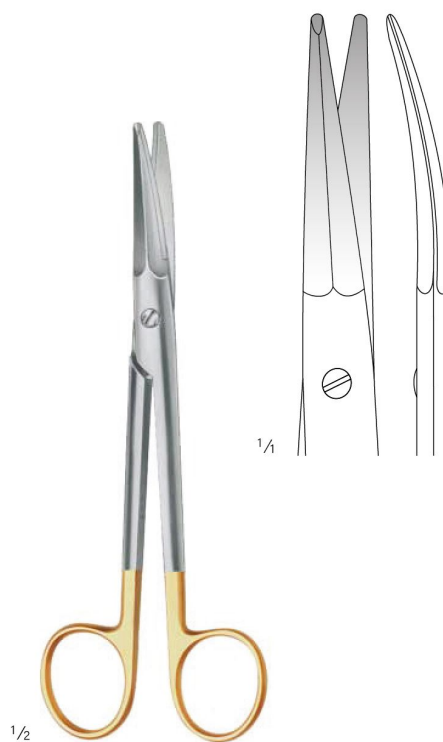

**Rees**  
**V 02-573-18**

17 cm / 6 5/8"  
 eine Schneide gezahnt  
 one toothed cutting edge  
 una hoja dentada  
 une lame dentelée  
 una lama dentata

**Gorney**

**V 02-572-20**  
**V 02-572-23**

eine Schneide gezahnt  
 one toothed cutting edge  
 una hoja dentada  
 une lame dentelée  
 una lama dentata

**Uterine Scissors**  
 Uterusscheren  
 Tijeras uterinas  
 Ciseaux utérins  
 Forbici uterine



	TC Gold	Super Cut TC	TCC BlackLine
22 cm / 8 5/8"	V02-574-22	V02-575-22	V02-576-22

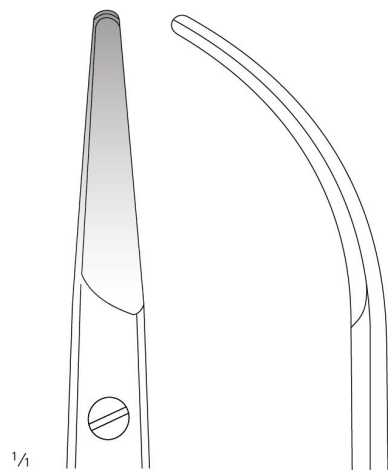

**Uterine Scissors**  
 Uterusscheren  
 Tijeras uterinas  
 Ciseaux utérins  
 Forbici uterine



02



	TC Gold	Super Cut TC	TCC BlackLine
23 cm / 9"	V02-577-23	V02-578-23	V02-579-23

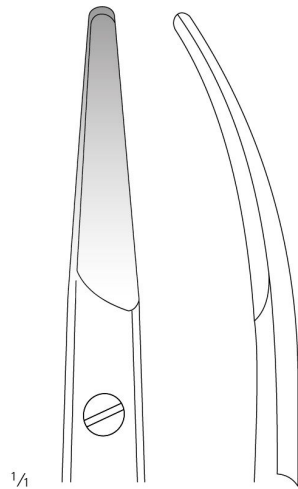

**Angled Scissors**  
 Winkelscheren  
 Tijeras acodadas  
 Ciseaux coudés  
 Forbici angolate



TC GOLD

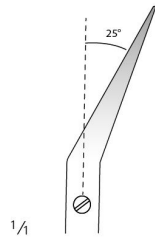

**V 02-580-19**  
 19 cm / 7 5/8"

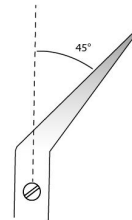

**V 02-581-18**  
 18,5 cm / 7 2/8"

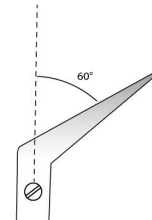

**V 02-582-18**  
 18 cm / 7 1/8"



1/2

**De Bakey**  
**V 02-580-19**  
 to  
**V 02-585-22**

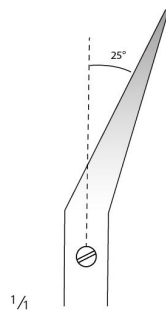

**V 02-583-23**  
 23 cm / 9"

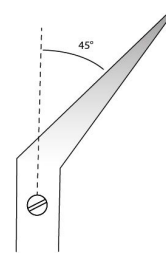

**V 02-584-23**  
 23 cm / 9"

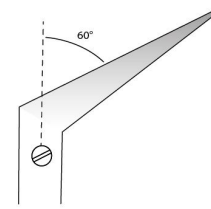

**V 02-585-22**  
 22 cm / 8 5/8"



## Dissecting Scissors, Wire Cutting Scissors

Präparierscheren, Drahtscheren

Tijeras de disección, Tijeras para cortar hilos de acero

Ciseaux à dissection, Ciseaux coupe-fil

Forbici per dissezione, Forbici per tagliare fili metallici



02



TC GOLD



### Ragnell

V 02-586-12

12,5 cm / 4 7/8"

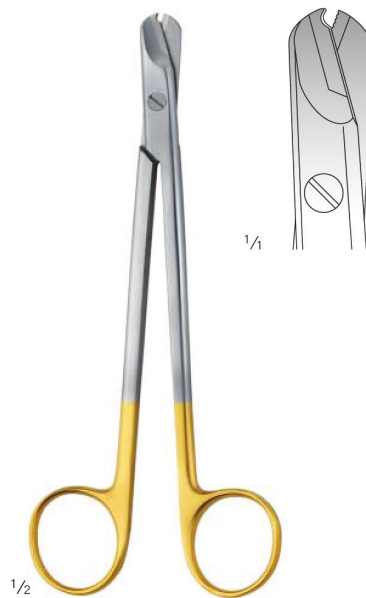

### Martin

V 02-587-16

16 cm / 6 2/8"

Drahtschere  
Wire cutting scissors  
Tijera para alambre  
Ciseaux à fils  
Forbici per fili

max Ø = 0,5 mm  
weicher Draht  
hard wire  
alambre duro  
fil métallique raide  
filo rigido



116



**no one does it BETTER**



**Cell:** +92 334 6113800

**URL:** <https://vorlinginstruments.com>

**Email:** [info@vorlinginstruments.com](mailto:info@vorlinginstruments.com)

**Address:**

Kacha Shahab Pura Road

Jeewan Pura, Sialkot (51310)

Pakistan.

